

8-9-2006

## An Effective Dynamic Handoff Support for Mobile Media Network

Aravinth Nallusamy  
*University of New Orleans*

Follow this and additional works at: <https://scholarworks.uno.edu/td>

---

### Recommended Citation

Nallusamy, Aravinth, "An Effective Dynamic Handoff Support for Mobile Media Network" (2006). *University of New Orleans Theses and Dissertations*. 410.  
<https://scholarworks.uno.edu/td/410>

This Thesis is protected by copyright and/or related rights. It has been brought to you by ScholarWorks@UNO with permission from the rights-holder(s). You are free to use this Thesis in any way that is permitted by the copyright and related rights legislation that applies to your use. For other uses you need to obtain permission from the rights-holder(s) directly, unless additional rights are indicated by a Creative Commons license in the record and/or on the work itself.

This Thesis has been accepted for inclusion in University of New Orleans Theses and Dissertations by an authorized administrator of ScholarWorks@UNO. For more information, please contact [scholarworks@uno.edu](mailto:scholarworks@uno.edu).

AN EFFECTIVE DYNAMIC HANDOFF SUPPORT FOR MOBILE  
MEDIA NETWORK

A Thesis

Submitted to the Graduate Faculty of the  
University of New Orleans  
in partial fulfillment of the  
requirements for the degree of

Masters of Science  
in  
The Department of Computer Science

By

Aravinth Kumar Nallusamy

B.E, Annamalai University, India, 2002

August, 2006

Copyright 2006, Aravinth Kumar Nallusamy

## **Acknowledgement**

I wish to express my gratitude to a number of people who became involved with this thesis, one way or another.

I am deeply indebted to my Thesis Advisor, Dr. Ming-Hsing Chiu for the advice, help and encouragement at the time of research and writing of this thesis. This work was accomplished after one year of research and hard fought times of Hurricane Katrina.

In addition, I would like to thank Dr. Adlai DePano and Dr. Golden G. Richard III for being on my thesis defense committee.

Finally, I would like to thank my family and friends for the continuous support and help they provided to me. I would like to dedicate this thesis to my parents .

## TABLE OF CONTENTS

|   |      |
|---|------|
| List of Tables .....                            | vi   |
| List of Figures .....                           | vii  |
| List of Abbreviations .....                     | viii |
| Abstract .....                                  | ix   |
| 1. Introduction .....                           | 1    |
| 1.1 Objective .....                             | 4    |
| 1.2 Problem Definition .....                    | 5    |
| 1.3 Organization of the Report .....            | 5    |
| 2. Project Overview .....                       | 6    |
| 2.1 Introduction .....                          | 6    |
| 2.1.1 System Purpose .....                      | 6    |
| 2.1.2 System Scope .....                        | 6    |
| 2.1.3 Chapter Overview .....                    | 6    |
| 2.2 General System Description .....            | 7    |
| 2.2.1 System Context .....                      | 7    |
| 2.2.2 Major System Capabilities .....           | 7    |
| 2.3 System Features .....                       | 7    |
| 2.3.1 Transcoder Controlled Handoff .....       | 7    |
| 2.3.1.1 Description .....                       | 7    |
| 2.3.1.2 Stimulus/Response Sequence .....        | 9    |
| 2.3.2 Client Controlled Handoff .....           | 9    |
| 2.3.2.1 Description .....                       | 9    |
| 2.3.2.2 Stimulus/Response Sequence .....        | 10   |
| 2.3.3 Content Server Controlled Handoff .....   | 10   |
| 2.3.3.1 Description .....                       | 10   |
| 2.3.3.2 Stimulus/Response Sequence .....        | 10   |
| 2.3.4 Performance Requirements .....            | 11   |
| 2.4 System Function .....                       | 11   |
| 2.4.1 Information Flows .....                   | 11   |
| 2.4.1.1 Functional requirement 1: sses .....    | 12   |
| 2.4.1.2 Functional requirement 2: tses .....    | 13   |
| 2.4.1.3 Functional requirement 3: tsis .....    | 14   |
| 3. Design and Test Plan .....                   | 15   |
| 3.1 Detailed Design .....                       | 15   |
| 3.1.1 System Structure .....                    | 15   |
| 3.2 Decomposition Description .....             | 15   |
| 3.2.1 Module Decomposition .....                | 15   |
| 3.2.1.1 Transcoder Controlled Handoff .....     | 16   |
| 3.2.1.2 Client Controlled Handoff .....         | 18   |
| 3.2.1.3 Content Server Controlled Handoff ..... | 19   |

|         |  |    |
|---------|--|----|
| 3.3     | Dependency Description .....           | 19 |
| 3.3.1   | Intermodule Dependencies .....         | 19 |
| 3.3.2   | Interface Description .....            | 20 |
| 3.3.2.1 | Module Interface .....                 | 20 |
| 3.3.2.2 | Module Description .....               | 21 |
| 3.4     | Module Design .....                    | 22 |
| 3.4.1   | System Overview .....                  | 22 |
| 3.4.1.1 | Transcoder Controlled Handoff .....    | 23 |
| 3.4.1.2 | Client Controlled Handoff .....        | 26 |
| 3.4.1.3 | Content Server Controlled Handoff..... | 28 |
| 3.5     | Testing.....                           | 29 |
| 3.5.1   | Validate Test case .....               | 29 |
| 4       | Implementation and Results.....        | 31 |
| 4.1     | Implementation Details .....           | 31 |
| 4.1.1   | Class Details .....                    | 31 |
| 4.1.2   | Snap Shots .....                       | 33 |
| 4.2     | Result .....                           | 37 |
| 4.3     | Performance Testing .....              | 40 |
| 5.      | Conclusion .....                       | 42 |
|         | References .....                       | 43 |
|         | Vita.....                              | 44 |

## LIST OF TABLES

|                                   |    |
|-----------------------------------|----|
| Table 3.1 Module Interface .....  | 20 |
| Table 3.2 Validate Test case..... | 29 |

## LIST OF FIGURES

|      |   |    |
|------|---|----|
| 1.1  | High Bandwidth requirement with conventional multi-resolution media .....       | 1  |
| 1.2  | Lower core bandwidth requirement with Content Transcoding Service.....          | 2  |
| 1.3  | Transcoding Handoff Setup .....   | 4  |
| 2.1  | Level 0 DFD for Handoff Mechanism .....   | 11 |
| 2.2  | Level 1 DFD for Handoff Mechanism .....   | 11 |
| 2.3  | Level 1.1 DFD for Single Step Explicit Switch.....                              | 12 |
| 2.4  | Level 1.2 DFD for Two Step Explicit Switch.....                                 | 13 |
| 3.1  | Module Decomposition .....  | 17 |
| 3.2  | Inter Module Dependency .....   | 20 |
| 3.3  | State 0 State Diagram for New/Handoff Connection.....                           | 22 |
| 3.4  | State 1 State Diagram for New Connection.....                                   | 22 |
| 3.5  | State 2.1 State Diagram for Transcoder Controlled Handoff .....                 | 24 |
| 3.6  | State 2.2 State Diagram for Client Controlled Handoff .....                     | 26 |
| 3.7  | State 2.3 State Diagram for Content Server Controlled Handoff .....             | 29 |
| 4.1  | Base Station Creation .....   | 33 |
| 4.2  | Mobile Unit Creation.....   | 34 |
| 4.3  | File Transfer from BTS1 .....   | 34 |
| 4.4  | Handoff from BTS1 to BTS2.....  | 35 |
| 4.5  | MU received file from BTS-2.....  | 35 |
| 4.6  | Content Server overloading method.....  | 36 |
| 4.7  | Client Controlled Handoff – Data Transfer rate verses Delay in ms .....         | 37 |
| 4.8  | Transcoder Controlled Handoff – Data Transfer rate verses Delay in ms .....     | 38 |
| 4.9  | Client Controlled Handoff – Data Transfer rate verses % of Packet Loss .....    | 38 |
| 4.10 | Transcoder Controlled Handoff –Data Transfer rate verses % of Packet Loss ..... | 39 |
| 4.11 | Overallperformance.....   | 39 |



## LIST OF ABBREVIATIONS

|      |                                   |
|------|-----------------------------------|
| TS   | Transcoding Server                |
| CS   | Content Server                    |
| TCH  | Transcoder Controlled Handoff     |
| CCH  | Client Controlled Handoff         |
| CSCH | Content Server Controlled Handoff |
| SSES | Single Step Explicit Switch       |
| TSES | Two Step Explicit Switch          |
| TSIS | Two Step Implicit Switch          |
| GOP  | Group of Picture boundary         |
| BS   | Base Station                      |
| MH   | Mobile Host                       |
| DGCS | Dynamic Guard Channel Scheme.     |
| RTP  | Real Time Protocol                |

## ABSTRACT

Mobility is the most important feature of a wireless cellular communication system. Usually, continuous service is achieved by supporting handoff (or handover) from one cell to another. Handoff is the process of changing the channel associated with the current connection while a call is in progress. It is often initiated either by crossing a cell boundary or by deterioration in quality of the signal in the current channel.

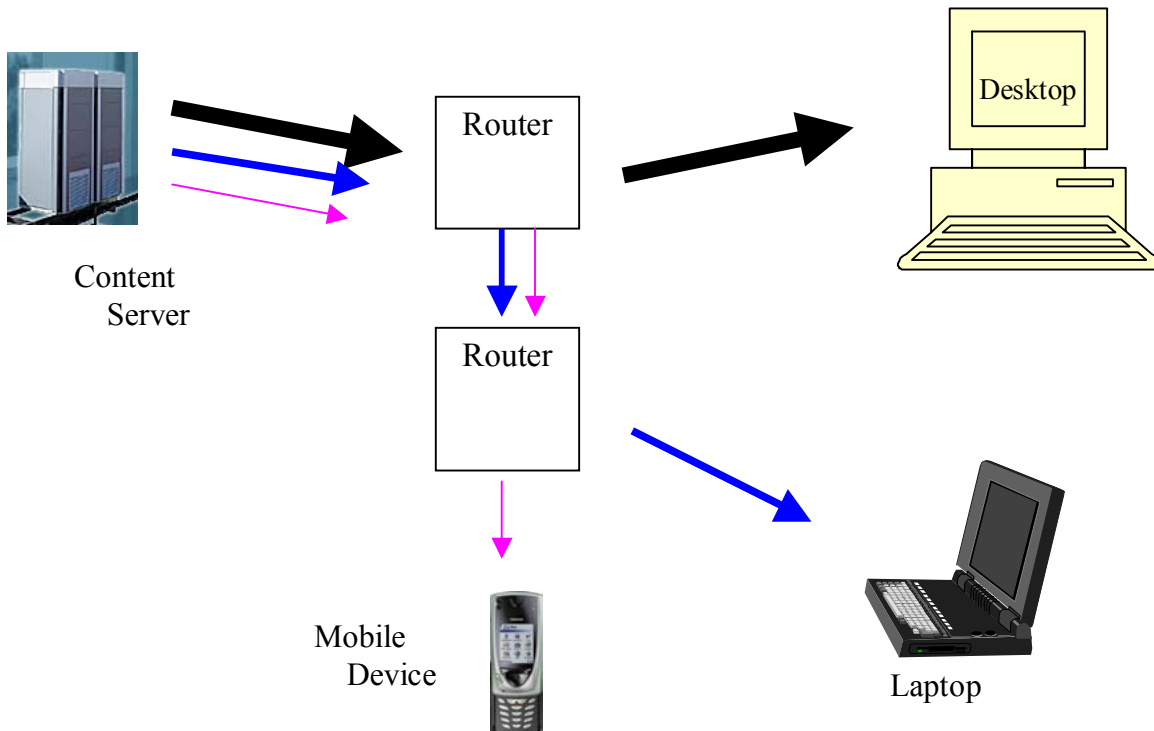
In this thesis, the different types of handoff controlled mechanisms are proposed and analyzed by passing the parameters offset address, Header information associated with the file, bit rate and bit resolution. The objective is to have an effective algorithm which provides a seamlessly migrate the session so that it stays close to the client, thus providing high quality video to the user. The implementation provides all the different types of hanoff techniques possible and a exclusive performance study has been done on all these techniques providing the benefit and the drawbacks of each approach.

# CHAPTER 1

## INTRODUCTION

Mobility is the most important feature of a wireless cellular communication system. Usually, continuous service is achieved by supporting handoff (or handover) from one cell to another. Handoff is the process of changing the channel (frequency, time slot, spreading code, or combination of them) associated with the current connection while a call is in progress. It is often initiated either by crossing a cell boundary or by deterioration in quality of the signal in the current channel.

The critical problems arise are as follows: Consider a conventional video streaming with the streams located at the Content server, as shown in Fig 1.1. If the service has to support clients with different display sizes and available bandwidth

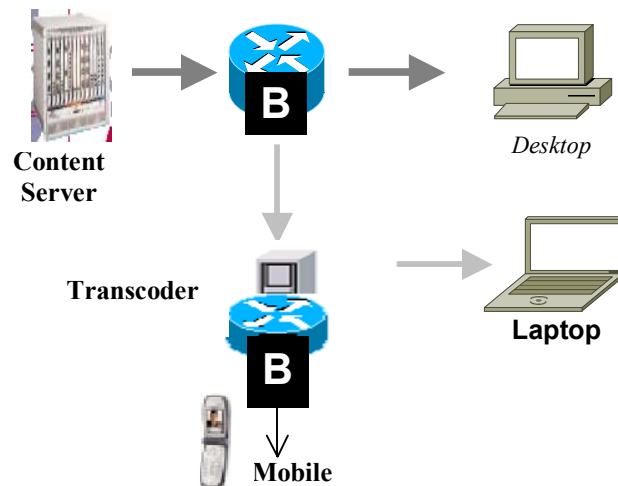


**Figure 1.1: High bandwidth requirement with conventional multiresolution media on Content Server**

e.g. desktops, laptops, mobile clients multi-resolution copies of the video stream have to be created and streamed from the content server, via the router, to the different clients. Hence the bandwidth requirement is high.

The second problem is that when there is mobility in a client during session, which causes the current transcoding server to be inefficient for the client's new location.

To solve the first problem a transcoding service could be provided on media processing units. When the client with different capabilities access the same content, only one stream needs to be sent from the origin server. The content with lower bit rate and bit resolution is created as close to the edge of the network as possible as shown in the Fig.1.2.



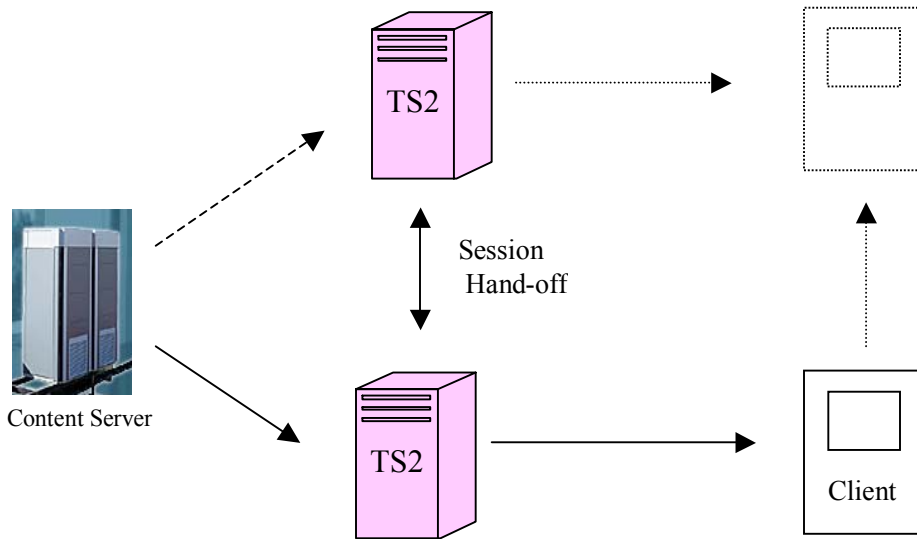
**Figure 1.2: Lower core bandwidth requirements with Content Transcoding Service**

By reducing the bandwidth requirement in the network core, the loss probability of packets in the video stream is also reduced.

## Transcoding server

Transcoding – manipulating the content on-the-fly in order to adapt to different terminal and network conditions, (2) selection – storing, selecting and delivering different variations of the content from a content server, (3) progressive retrieval –providing scalable representations of audio-visual signals that allow them to be retrieved progressively, and (4) summarization – providing personalized summaries of audio-visual programs that allow mobile users to efficiently browse and view the content. Transcoding has the advantage of not requiring the storage of excess data at the server. However, transcoding does require processing of the content, such as at a server or proxy, which typically introduces delay. On the other hand, pre-materialization of different variations of the content increases the amount of data that needs to be stored at the server, but it typically requires the different variations to be selected without processing of the content, thereby resulting in less delay.

The second problem is solved as follows: The client initially requests a video stream from the Transcoding Server 1(TS1). This server requests the full resolution, high bit rate stream from the content server. After the Content Server starts sending the video, Transcoding Server 1 reduces the resolution and bit rate of the video streams and forwards it to the Mobile Client. When the TS1 receives a notification that the client has moved away from it, and closer to some other Transcoding Server (TS2), it initiates a Session Handoff handshake. This is shown in the Fig:1.3. TS2 requests the same video stream from a Content Server. Once the second server starts transcoding and streaming to the Mobile Client, TS1 can shut down its own session. This mechanism is known as Transcoder Controlled Handoff mechanism.



**FIG 1.3 Transcoding Handoff Setup**

The handoff could be even initiated by the Client or by the Content Server. After initiation, the actual protocol could also be controlled by any of these entities.

The parameters to be passed during the handoff are: offset address, Header information associated with the file, bit rate and bit resolution. The performance analysis of different handoff mechanisms will be reported.

## **1.1 OBJECTIVE**

The objective is to seamlessly migrate the session so that it stays close to the client, thus providing high quality video to the user. Transcoding Service could be provided to reduce the bandwidth requirement in the network core. Also the system have the following features:

- Provide Load-balancing at the transcoder.
- Add Fault tolerance.

- Reduces the bandwidth and delay

#### Previous work

There has been lot of research done on the reduction of quality of the streaming video for the mobile clients, but there is not much work done on the handoff technique. The [2] did some basic work on the hand-off techniques but didn't provide a strong conclusion on the techniques. So taking this as the basic idea, worked on implementing algorithm and test cases to prove the hand-off techniques with the conclusion and the places where more improvement can be done.

## **1.2 PROBLEM DEFINITION**

Application level Handoff implemented has the disadvantage of requiring high bandwidth for different clients [3]. By reducing the bandwidth requirement we can reduce the loss probability of the packet in the video stream is also reduced [2].

The quality of the video streaming may be lost due to handoff. This can be overcome by providing priority to the handoff connection [5].

## **1.3 ORGANIZATION OF THE REPORT**

The reminder of this report is organized as follows: Chapter 2 deals with the Project Overview for the project. Chapter 3 outlines the Design Details pertaining to the project. Chapter 4 gives details about the Implementation, Results and Discussions pertaining to the sample inputs and screen shots displayed. Chapter 5 gives the conclusion and the future Enhancements that could be improved of the project.

## CHAPTER 2

### PROJECT OVERVIEW

#### 2.1 INTRODUCTION

##### 2.1.1 System Purpose

This document states the requirements for an application that provides An Effective Dynamic Handoff Support for Mobile Media Network. The requirements stated serve to produce a system to provide a high quality video to the user with low bandwidth and delay. It also serves to provide load balancing and fault tolerance in the mobile computing environment.

##### 2.1.2 System Scope

The intended “**An Effective Dynamic Handoff Support for Mobile Media Network**” will provide high quality services to the user when the client is in transition.

##### 2.1.3 Chapter Overview

This chapter provides a general introduction of dynamic handoff mechanism in wireless networks. Section 2 gives a general description of system functions and constraints. Section 3 describes the specific requirements of the functions. Section 4 gives the system features. Section 5 gives the system functions in detail.



## **2.2 GENERAL SYSTEM DESCRIPTION**

### **2.2.1 System Context**

Deploying different handoff mechanisms can solve the vulnerabilities in mobile computing. This system requires less processing overhead at the client, and requires minimal buffering. By reducing bandwidth requirements in the network core the loss probability of package in the video stream is also reduced.

### **2.2.2 Major System Capabilities**

This system provides the following functions:

2.2.2.1 Mobile computing environment to work.

2.2.2.2 A solution to the problem of application level handoff for supporting video transcoding session to the mobile clients.

2.2.2.3 Handoff schemes to provide load balancing at the transcoder level.

## **2.3 SYSTEM FEATURES**

Feature 1: Transcoder controlled handoff

Feature 2: Content server controlled handoff

Feature 3: Client controlled handoff

Feature 4: Performance analysis

### **2.3.1 Transcoder Controlled Handoff**

#### **2.3.1.1 Description**

In this module, the **transcoding server initiates the handoff** during client transition. Signal strength from different base stations are compared by the client and report is sent to the

transcoding server. This measurement report will not be used by TSIS, as it pre-agrees with the transcoding server. The transcoding server decides to switch over to another transcoding server, which will be nearer to the client. Quality will be maintained. The following three methods are used for this module.

1. Single Step Explicit Switch (SSES):

TS1 sent the state information to TS2. TS2 request the same content from the Content Server. Once the Content Sever starts streaming the original video to TS2, it creates and transmits the transcoded stream to the client.

TS1 stops transcoding as soon as it initiates the transfer. TS2 can proceed with its session by the explicit arrival of the state information. Hence some amount of delay may occur which is a tolerable delay.

2. Two Step Explicit Switch (TSES):

Once the TS1 decides to handoff, it sent handoff message along with the content information and the offset to the TS2. TS2 can contact the Content Server for the video stream. At the same time, partial state information is sent to TS2. TS1 then finishes transcoding the current frame. After sending the last packet to the client, TS1 sends a switch message to the TS2 along with the final state information.

3. Two Step Implicit Switch (TSIS):

The key issue here is that the transcoders assumes that the handoff will always occurs at a GOP boundary. GOP boundary will be pre-agreed between the transcoding servers. Hence there is no need to send any state information, which reduces further delay. The possible drawback of this method is that the delay term can be negative. Having a reordering buffer can solve the problem. No state's information will be sent to the new TS which reduces the delay.

### 2.3.1.2 Stimulus/ Response Sequences

#### Stimulus

- To reduce delay
- Provide load balancing at the transcoder
- To add fault tolerance

#### Response

Input : Measurement report from the client.

Output: State Information.

### 2.3.2 Client Controlled Handoff

#### 2.3.2.1 Description

In this module, the **Client initiates the handoff**. Packet loss at the client side and the signal strength from different base stations are compared by the client. According to that it decides to switch over to another transcoding server, which is nearer to the client. These measurement reports are used only by the SSES and TSES. Client request the state information from the transcoding server and sent it to the new transcoding server. Three different methods are as follows:

1. Single Step Explicit Switch (SSES):

Client request the state information from the transcoding server and pass this information's to the new transcoding server. Delay may occur which is a tolerable delay.

2. Two Step Explicit Switch (TSES):

The state information's are transferred to the new transcoding server via the client from the current transcoding server. Partial state information will be sent. At the same time the information from the old transcoding server will be sent to the client, which reduces some amount of delay.

3. Two Step Implicit Switch (TSIS):

GOP boundary is fixed between the transcoding servers. When the client moves away from the boundary, handoff occurs. Delay may be reduced compared to other two methods.

### **2.3.2.2 Stimulus / Response Sequence**

#### **Stimulus**

- To Reduce Packet loss
- To reduce delay

#### **Response**

Input : Packet loss, Signal strength

Output : State Information

### **2.3.3 Content Server Controlled Handoff**

#### **2.3.3.1 Description**

In this module, the **Content Server initiates the handoff**. Content Server receives overloading signal from the transcoding server or there may be failure of TS. In this situations, the Content Server decides to handoff. The Content Server send the original video stream to the new transcoder.

The Content Server has more responsibility, as it should maintain the information about the transcoding servers.

#### **2.3.3.2 Stimulus / Response Sequence**

**Stimulus:** To reduce delay

#### **Response**

Input : Overloading signal, Signal strength

Output : State Information

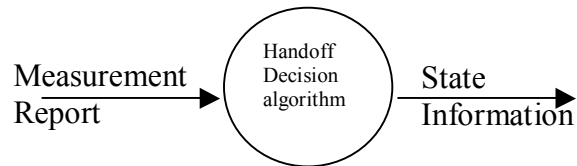
### 2.3.4 Performance Requirements

- To improve the quality.
- Delay has to be red

## 2.4 SYSTEM FUNCTION

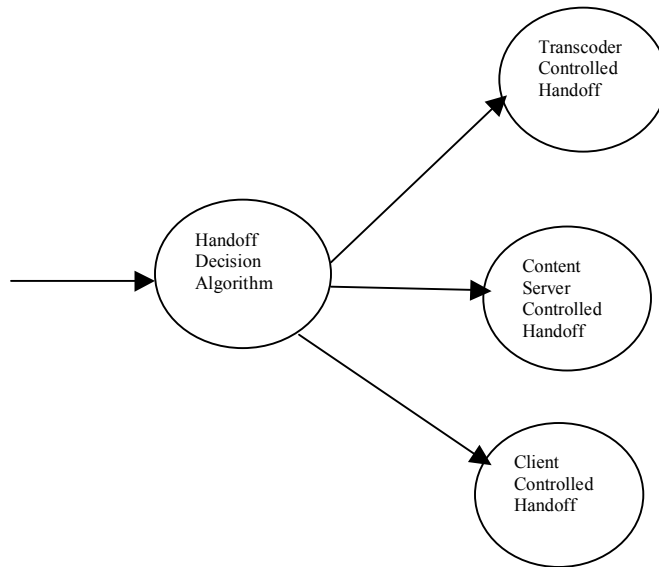
### 2.4.1 Information flows

Level 0



**FIG 2.1 Level 0 DFD for Handoff Mechanism**

Level 1:



**FIG 2.2 Level 1 DFD for Handoff Mechanism**

### 2.4.1.1 Functional Requirement1: Single Step Explicit Switch (SSES)

#### Level 1.1

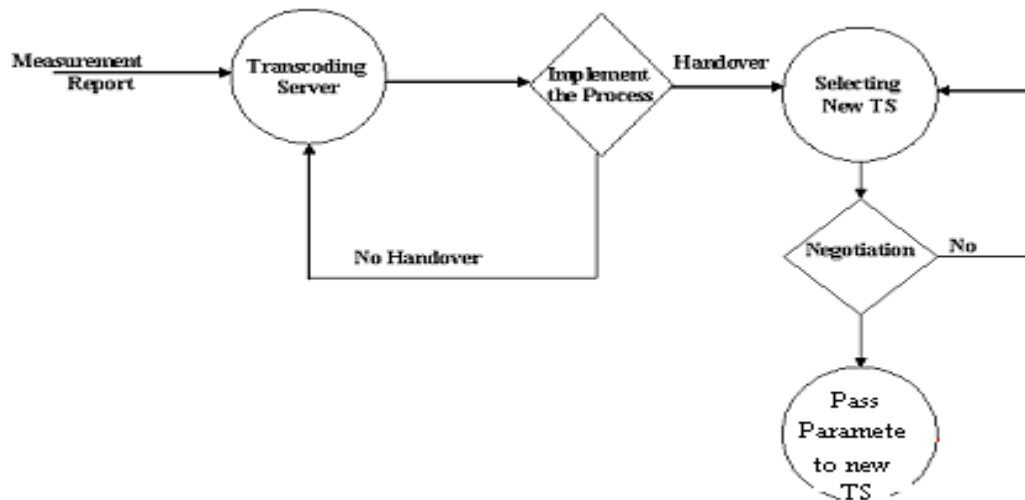


FIG 2.3 Level 1.1 DFD for Single Step Explicit Switch

**Input :** Measurement report is sent to the transcoding server.

**Processing:** In TCH mechanism, the signal strength is compared with the threshold value. If it is less then the TS decides to handoff, otherwise handover need not take place. In CCH mechanism, Client decides to handoff if it sees lot of packet loss in the stream arriving from the transcoder, or if it receives a signal from the transcoder to switch over to another transcoder.

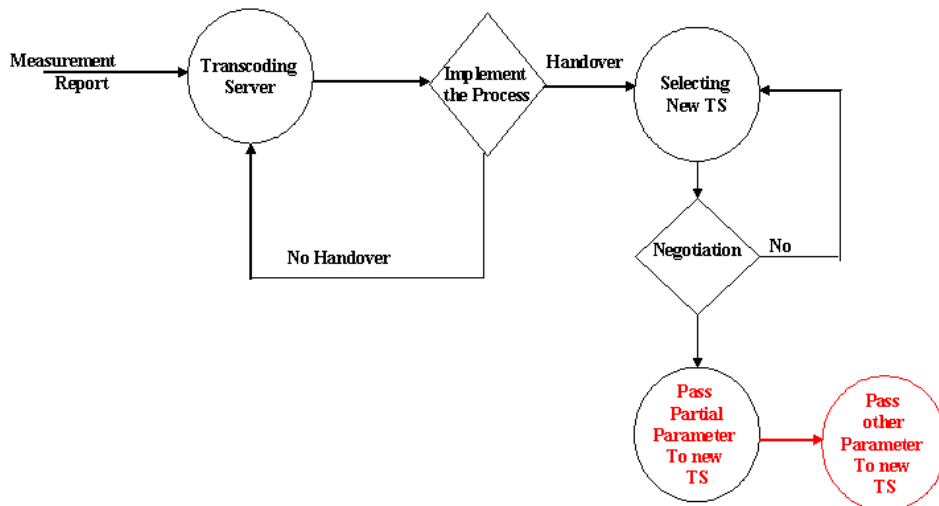
**Output :** State information are sent to the new Transcoder by the current TS or Client as shown in Fig 2.3

### 2.4.1.2 Functional Requirement 2: Two Step Explicit Switch(TSES)

**Input :** Client sent a measurement report to the TS.

**Processing:** In CCH, the client decides to handoff when there may be any loss of packets. The TS decides to handoff when it receives a signal strength report from the client. It does so only when the signal strength is less than the threshold value. Otherwise, handover need not take place.

#### Level 1.2



**FIG 2.4 Level 1.2 DFD for Two Step Explicit Switch**

**Output :** Initially partial state's information are passed to the new TS as shown in Fig 2.4. At the same time packets are sent from the old TS. After sending the last packet to the client from the old TS, the final state's information are sent, which reduces the delay.

### **2.4.1.3 Functional Requirement 3: Two Step Implicit Switch (TSIS)**

**Input :** GOP boundary value is fixed based on the history.

**Processing:** When client moves beyond the GOP boundary, handoff will be decided by the corresponding handoff mechanism.

**Output :** sending pre agreement about group of picture (GOP) boundary



## **CHAPTER 3**

### **DESIGN AND TEST PLAN**

#### **3.1. DETAILED DESIGN**

##### **3.1.1 System Structure**

The System challenges to seamlessly migrate the session so that it stays close to the client, thus providing high quality video to the user. Transcoding Service could be provided to reduce the bandwidth requirement in the network core. By reducing the bandwidth requirement, the loss probability of packets in the video streaming is also reduced.

Handoff could be initiated by the Client, the Content Server or by the Transcoding Server. The different Handoff Controlled mechanism performances are measured and analyzed.

#### **3.2 DECOMPOSITION DESCRIPTION**

##### **3.2.1 Module Decomposition**

1. Transcoder Controlled Handoff
  - a. Single Step Explicit Switch (SSES)
  - b. Two Step Explicit Switch (TSES)
  - c. Two Step Implicit Switch (TSIS)

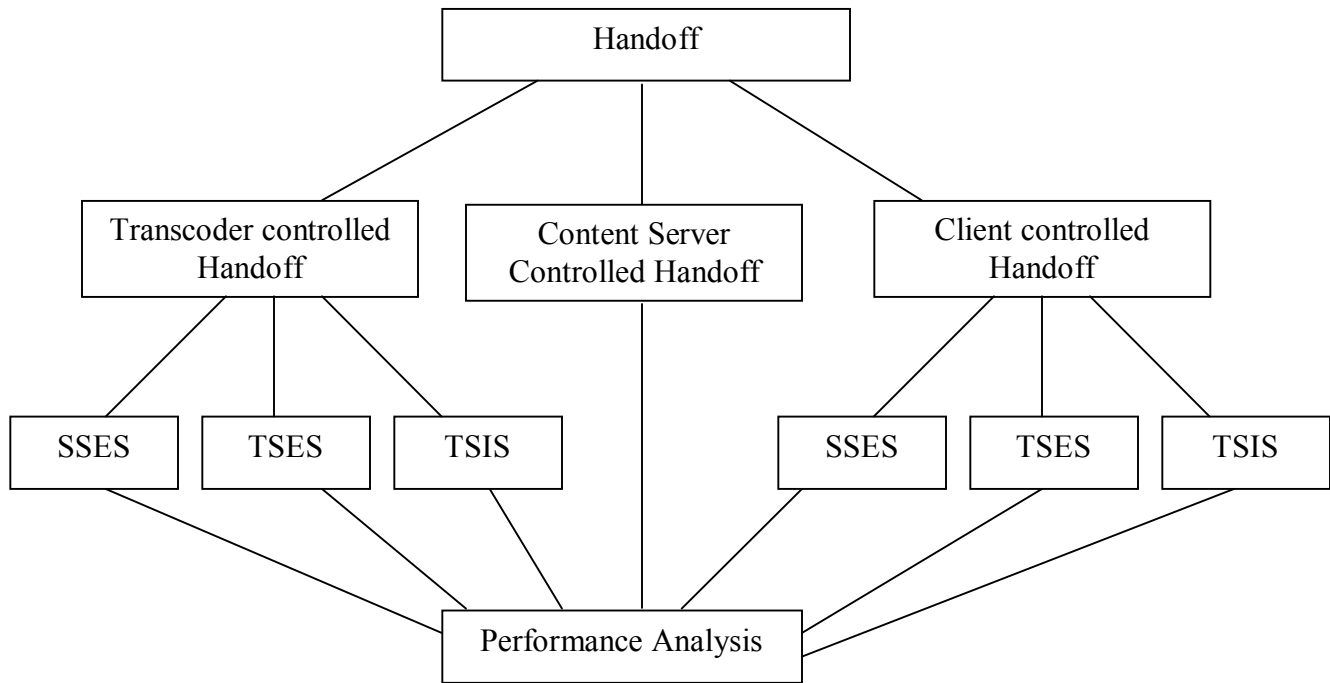
2. Content Server Controlled Handoff
  - a. Single Step Explicit Switch (SSES)
3. Client Controlled Handoff
  - a. Single Step Explicit Switch (SSES)
  - b. Two Step Explicit Switch (TSES)
  - c. Two Step Implicit Switch (TSIS)
4. Performance Analysis

### **3.2.1.1 Transcoder Controlled Handoff**

In a Transcoder Controlled handoff process, the MH makes measurements and the Transcoding Server (BS) makes the decision. The Base Station Controller is in charge of the handoff management.

The MH receives signal from different BS and sends the measurement report to the BS. If the signal strength of the existing BS is less then handoff has to be taken place.

This has to be decided by the BS, the Transcoding Server. Hence it is know as Transcoder Controlled Handoff.



**FIG 3.1 - Module Decomposition**

**3.2.1.1.1 Single Step Explicit Switch:**

In this approach, the MH sends a measurement report to the current BS (TS1). If handoff is needed state information (parameters) has to be passed to the new MH. The new BS (TS2) has to get the same stream from the Content server using the parameter and send from the offset value given by the old one. Here the delay become more as the TS1 stops Transcoding as soon as it initiates the transfer. Also TS2 can only proceed with its Transcoding session by the explicit arrival of the state information.

#### **3.2.1.1.2 Two Step Explicit Switch:**

In TSES, the TS1 starts the handoff, but waits until the current frame is finished before sending the final switch message.

#### **3.2.1.1.3 Two Step Implicit Switch:**

To further reduce the delay from the client, the switch happens at a GOP boundary that is relatively less time independent. There will be no explicit switching message from the TS1 to the TS2; rather, TS1 and TS2 pre-agree that the switch will happen at the next GOP boundary.

TS1 will stop transcoding at the next GOP boundary; on the other hand TS2 will start transmitting the transcoding results at the next GOP boundary.

#### **3.2.1.2 Client Controlled Handoff**

A MH (Client) may decide to handoff if it sees a lot of packet loss in the stream arriving from one BS, or if it receives a signal from the BS to switch to another BS.

##### **3.2.1.2.1 Single Step Explicit Switch**

Handoff is required due to more packet loss or if the MH receives a signal from one BS to another BS. The BS stops transcoding as soon as it initiates the transfer, and the new BS can only proceed with its transcoding session by the explicit arrival of the state information. Hence there may be long delay in this method

##### **3.2.1.2.2 Two Step Explicit Switch**

To reduce this delay, a handoff request may appear when the old BS is in the midst of transcoding a compressed frame. BS starts the handoff, but waits until the current frame is finished before sending the final switch message. That is, the state information is sent partially

first, at that time new BS will contact the Content Server and starts transcoding. After sending the last packet to the client, the old BS sends a switch message to the new BS along with the final state information.

#### **3.2.1.2.3 Two Step Implicit Switch**

To further reduce the delay from the client, the switch happens at a GOP boundary or some type of boundary that is relatively less time independent. There will be no explicit switching message from the TS1 to the TS2; rather, TS1 and TS2 pre-agree that the switch will happen at the next GOP boundary.

TS1 will stop transcoding at the next GOP boundary; on the other hand TS2 will start transmitting of transcoding results at the next GOP boundary.

#### **3.2.1.3 Content Server Controlled Handoff**

A Content Server may initiate a hand-off if it gets a signal from the Transcoder that it is overloaded. Hence the server maintains state information for all of its transcoding sessions. The server may have to update its state transformation from the old BS before it can send it to the new BS.

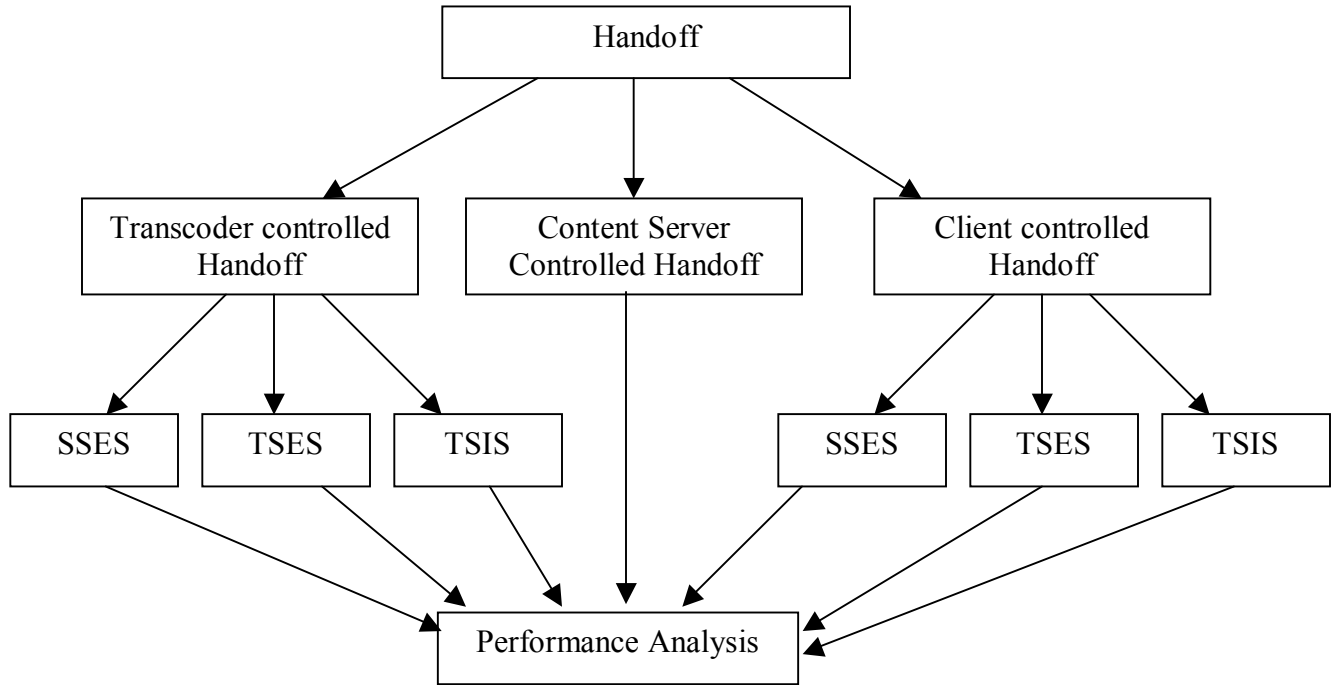
### **3.3 DEPENDENCY DESCRIPTION**

#### **3.3.1 Intermodule Dependencies**

Transcoder, Client or Content Server can do handoff. Hence the mechanisms are known as Transcoder Controlled Handoff, Client Controlled Handoff, and Content Server Controlled Handoff respectively. TCH and CCH mechanisms uses three different methods

1. Single Step Explicit Switch
2. Two Step Explicit Switch
3. Two Step Implicit Switch

These three handoff mechanisms' performance is analyzed



**FIG 3.2 - Inter Module Dependencies**

### 3.3.2 Interface Description

#### 3.3.2.1 Module Interface

| <b>Modules</b>                    | <b>Interface</b>                   |
|-----------------------------------|------------------------------------|
| Transcoder Controlled Handoff     | Signal Strength from client        |
| Content Server Controlled Handoff | Overloading Signal                 |
| Client Controlled Handoff         | Signal from BS, Due to Packet loss |

**Table 3.1 Module Interface**

### **3.3.2.2 Module Description**

Handoff is required when the movement of a MH causes the current BS to be inefficient for the Client's new location. The handoff could be initiated by the client, the transcoding server or by the Content Server. The actual protocol could also be controlled by any of these entities.

#### **3.3.2.2.1 Module1 description**

The Transcoding Server decides the handoff. The client will send a report to the Transcoding server. The transcoding server on receiving this measurement report decides to handoff. Three different methods are as follows:

- Single Step Explicit Switch (SSES)
- Two Step Explicit Switch (TSES)
- Two Step Implicit Switch (TSIS)

#### **3.3.2.2.2 Module2 description**

The Content server could initiate the handoff. That is, the content Server decides the handoff. As the content or the streams are available in the Content Server, there is no need to send any state transformation.

#### **3.3.2.2.3 Module3 description**

The handoff is decided by the client, as there may be more packet loss, poor signal strength. Client requests the state information from the old TS. Three different methods are as follows:

- Single Step Explicit Switch (SSES)
- Two Step Explicit Switch (TSES)
- Two Step Implicit Switch (TSIS)

### 3.4 MODULE DESIGN

#### 3.4.1 System overview

State Diagram:

State 0:

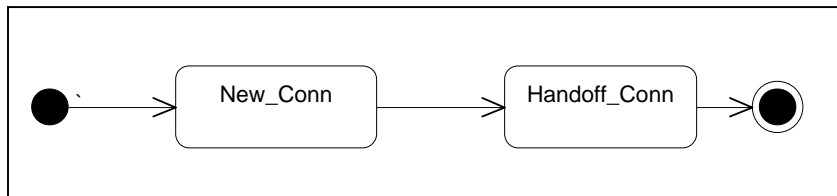


FIG 3.3 - State Diagram for New / Handoff Connection

*State 1: New Connection*

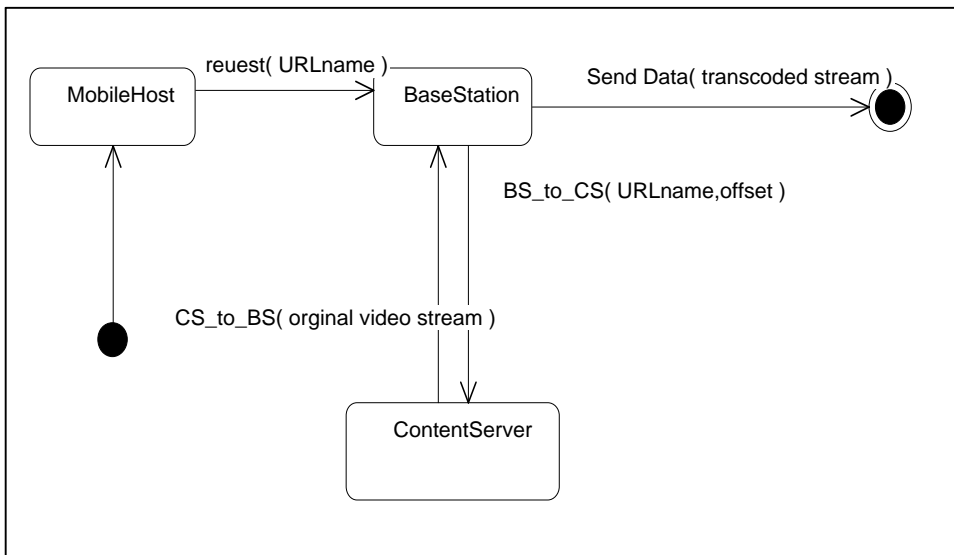


FIG 3.4 - State Diagram for New Connection



Handoff may be done in the following ways:

- Transcoder may decide to handoff (TCH)
- Client may initiate the handoff (CCH)
- Content Server may decide it (CSCH)

### **3.4.1.1 Transcoder Controlled Handoff**

#### **3.4.1.1.1 Single Step Explicit Switch**

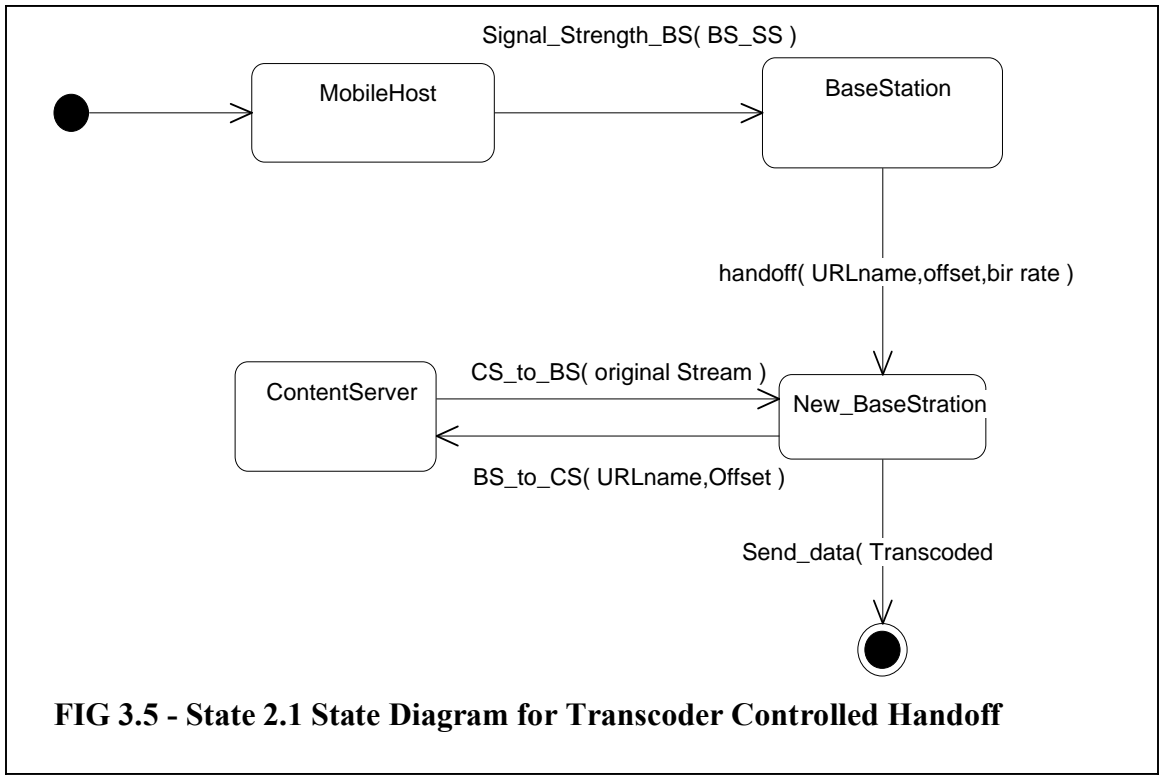
**Input:** Measurement Report from Client (MH) to the old Transcoding Server (BS).

**Processing:** The MH compares the incoming signal strength from different BS and the report is sent to the current BS. On receiving this, it checks for the threshold value. If the signal strength is less than the threshold then the BS decides to handoff.

**Output:** State information is passed to the new BS

**Algorithm:**

1. BS gets the measurement report from the MH (Client)
2. If ( signal strength < threshold )  
Decide to Handoff  
Else  
Continue with the old BS
3. Select new BS which is nearer to the Client
4. check for negotiation
5. If no BS available, go to step (3)
6. Pass Parameter to the new BS.
  - a. File type
  - b. Bit rate and Bit resolution
  - c. Offset value – current position in the video stream
7. Old BS stops transcoding as soon as it initiates the transfer. New BS proceeds with its transcoding by the explicit arrival of state information.



### 3.4.1.1.2 Two Step Explicit Switch

**Input:** Measurement Report from Client (MH) to the old Transcoding Server (BS).

**Processing:** The MH compares the incoming signal strength from different BS and the report is sent to the current BS. On receiving this, it checks for the threshold value. If the signal strength is less than the threshold then the BS decides to handoff.

**Output:**

1. Partial information is provided to the new BS i.e. File type alone
2. Bit rate, Bit resolution and the offset value is sent as a next message

**Algorithm:**

1. BS gets the measurement report from the MH (Client)
2. If ( signal strength < threshold )
  - Decide to Handoff
  - Else
  - Continue with the old BS

3. Select new BS which is near to the Client
4. Check for negotiation
5. If no BS available, go to step (3)
6. Partial Parameter sent to the new BS.
  - a. File type
7. Old BS finishes transcoding the current frame after sending the partial state information
8. Switch message and final state information's are passed to new BS

#### **3.4.1.1.3 Two Step Implicit Switch**

**Input:** Measurement Report from Client (MH) to the old Transcoding Server (BS).

**Processing:** The MH Compares the incoming signal strength from different BS and the report is sent to the current BS. On receiving this, it checks for the threshold value. If the signal strength is less than the threshold then the BS decides to handoff.

**Output:** GOP boundary to the new BS

**Algorithm:**

1. The transcoding servers pre-agree with each other (Switch happen at the next GOP.)
2. BS sends a start message to the new BS.
3. New BS request the video stream from the CS at the same time, old BS send the data to the MH
4. After establishing a connection with the Content Server new BS starts sending data immediately
5. Old BS stops transcoding as soon it initiates the transfer. New BS proceeds with its transcoding by the explicit arrival of state information.

### 3.4.1.2 Client Controlled Handoff

#### 3.4.1.2.1 Single Step Explicit Switch

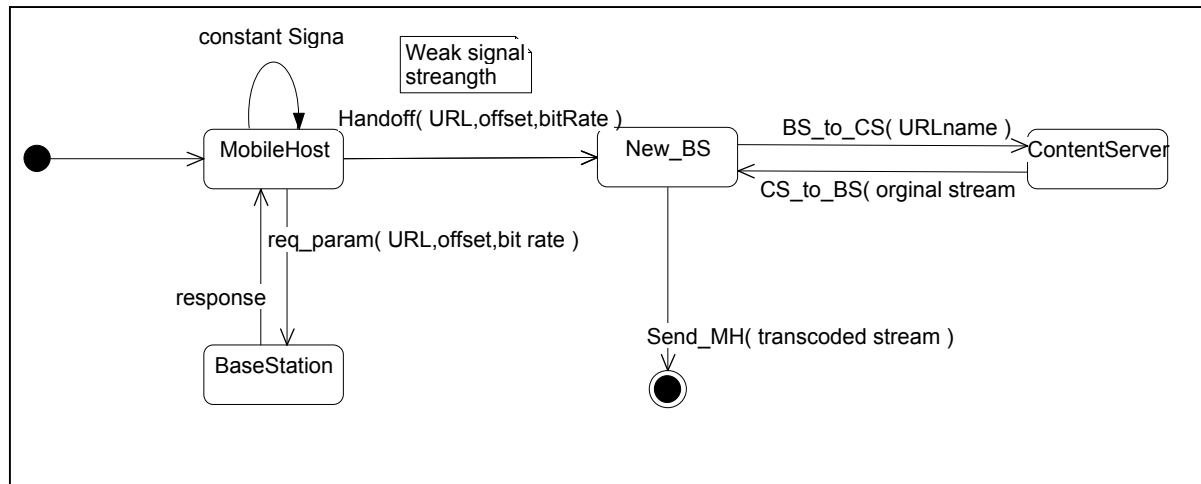
**Input:** Signal strength and Packet loss

**Processing:** The MH Compares the incoming signal strength from different BS. If the signal strength from the current BS is less than the threshold or any packet loss occurs, then the MH decides to handoff.

**Output:** State Information are passed to the new BS

**Algorithm:**

1. Check the signal strength and the packet loss rate.  
If ( signal strength < threshold )  
    Decide to Handoff  
Else Continue with the old BS
2. Select new BS
3. check for negotiation
4. If no BS available, go to step (3)
5. Pass Parameter to the new BS.
6. Old BS stops transcoding as soon it initiates the transfer. New BS proceeds with its transcoding by the explicit arrival of state information.



**FIG 3.6 - State 2.2 State Diagram for Client Controlled Handoff**

### 3.4.1.2.2 Two Step Explicit Switch

**Input:** Signal strength and Packet loss

**Processing:** The MH Compares the incoming signal strength from different BS. If the signal strength from the current BS is less than the threshold or any packet loss occurs, then the MH decides to handoff.

**Output:**

1. Partial information is provided to the new BS i.e. File type alone
2. Bit rate, Bit resolution and the offset value is passed as separate message

**Algorithm:**

1. Check the signal strength and the packet loss rate.
2. If (signal strength < threshold)
  - a. Decide to Handoff
- Else
  - b. Continue with the old BS
3. Select new BS which is near to the Client
4. Check for negotiation
5. If no BS available, go to step (3)
6. Partial Parameter sent to the new BS.
  - a. File type
7. Old BS finishes transcoding the current frame after sending the partial state information
8. Switch message and final parameters are passed to new BS
  - a. Bit rate and Bit resolution
  - b. Offset value – current position in the video stream

### 3.4.1.2.3 Two Step Implicit Switch

**Input:** Signal Strength or packet loss

**Processing:** The MH Compares the incoming signal strength from different Base Stations. If the signal strength from the current BS is less than the threshold or if any packet loss occurs, then the MH decides to handoff.

**Output:** GOP boundary to the new BS

**Algorithm:**

1. The transcoding servers pre-agree with each other (Switch happen at the next GOP.)
2. When Client decides to handoff, it notifies to the new and old BS
3. BS sends a start message to the new BS.
4. New BS requests the video stream from the CS, at the same time old BS sends the data to the MH.
5. After establishing a connection with the Content Server new BS starts sending data immediately.
6. Old BS stops transcoding as soon it initiates the transfer. New BS proceeds with its transcoding by the explicit arrival of state information.

**3.4.1.3 Content Server Controlled Handoff**

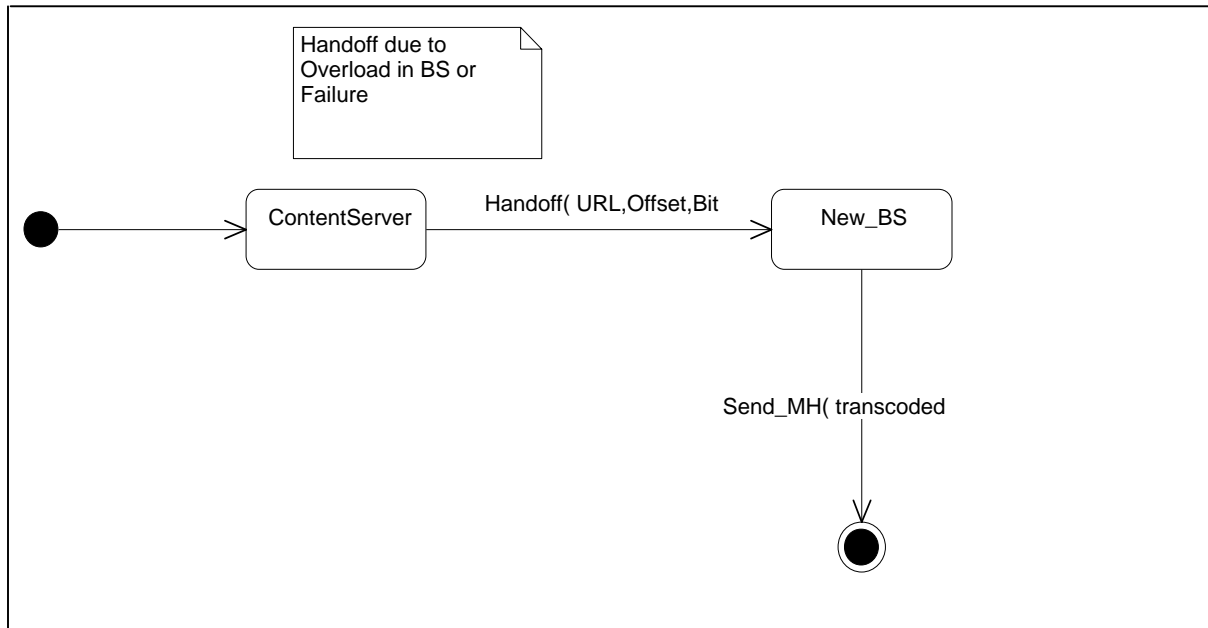
**Input:** Overloading signal from BS

**Processing:** Content server maintains the details about the entire BS. Also it updates whenever any modification occurs in the BS. Checks for the overloading signal. If overloading signal occurs, handoff is decided based on the type of Quality of Signal.

**Output:** Original stream to the new BS.

**Algorithm:**

1. Content Server receives an overloading signal from the BS.
2. If overloading signal found then  
    Decide to handoff  
    Else  
    Continue with the old BS.
3. Select new BS that is near to the Client
4. Check for negotiation
5. If no BS available, go to step (3)
6. Original video stream is passed to the new BS.
7. New BS starts transcoding the stream



**FIG 3.7 - State 2.3 State Diagram for Content Server Controlled Handoff**

### 3.5 TESTING

#### 3.5.1 Validate Test Case

| Test Case Id | Test Case                                  | Steps to execute the test case                 | Expected Results       | Actual Result    | Pass/Fail |
|--------------|--|--|------------------------|------------------|-----------|
| 1            | User request to check for the availability | Check for the availability of BSC              | BSC Not Exist          | BSC Not Exist    | Pass      |
| 2            | User request to check for the availability | Check for the availability of Base Station     | Base Station Not Exist | Not Exist        | Pass      |
| 3            | User request to check for the availability | Check for the availability of MU               | Mobile Unit Not Exist  | Not Exist        | Pass      |
| 4            | User request to check for the field values | Check all the field values are entered for BSC | Value Missing          | Enter all values | Pass      |
| 5            | User request to check for the field values | Check all the field values are entered for MU  | Value Missing          | Enter all values | Pass      |

| Test Case Id | Test Case  | Steps to execute the test case   | Expected Results                     | Actual Result                          | Pass/Fail |
|--------------|--|--|--------------------------------------|--|-----------|
| 6            | Check for Mobile unit availability                         | Check whether mobile unit exist while transferring the file                              | Mobile unit does not exists          | Mobile unit does not exists            | Pass      |
| 7            | Check the id of Base Station Controller                    | Check BSC value starts from 1001   | Not Available                        | BSC not available                      | Pass      |
| 8            | User request for duplicate values                          | Check BTS-id is already available  | Already Exists                       | The entry of BaseStation-id exist      | Pass      |
| 9            | User request for duplicate values                          | Check BSC id is already available  | Already Exists                       | The entry of BSC-id exist              | Pass      |
| 10           | User request to check Base station availability            | Check BTS is available before creating mobile Unit                                       | BTS not found                        | Base Station not found please re-enter | Pass      |
| 11           | Check for Mobile unit availability                         | Check weather mobile unit is with in the base station region while transferring the file | MU not in the region of Base station | MU not persists in the region of BTS   | Pass      |
| 12           | User request for duplicate values                          | Check MU-id is already available   | Already Exists                       | The entry of MU-id exist               | Pass      |
| 13           | User request to check Base Station Controller availability | Check BSC is available before creating Base Station                                      | BSC not found                        | BSC not found                          | Pass      |
| 14           | Check for Mobile unit availability                         | Check weather at least one mobile unit is present before moving                          | Create atleast one Mobile Unit       | Create atleast one Mobile Unit         | Pass      |
| 15           | Check the number of mobile unit in BTS                     | Check weather the BTS is not overloaded  | BTS overloaded                       | Cannot add new MU, BTS is overloaded   | Pass      |

**Table 3.2 Validate Test case**



## CHAPTER 4

### IMPLEMENTATION AND RESULTS

#### 4.1 Implementation Details

**“An Effective Dynamic Handoff Support for Mobile Media Network”** is implemented using Java Swing. Created own simulator using Swing. Java Bean is used to set the properties of the base station, Mobile client and Base Station Controller. Used separate Package for network such as socket connection between the services. Socket pooling is used for base station controller and base station as they behave both as a Client as well as a Server. Base Station Controller acts as a client with the Content Server and acts as a Server with the Base station.

##### 4.1.1 Class Details:

MySim is the main class that calls Simulator class. The sample class files and the snap shots are shown:

```
class MySim
{
    Simulator()
}
```

```
class Simulator()    // For GUI
{
    Simulator()
    viewBsc()
    viewBst()
    viewMst()
    checkPersist(MobileUnitBean) // Checking whether the client is with in the region
}
\
```

```

class SimTimer
{
    start_time
    end_time
    delay
    SimTimer() // Constructor for starting separate thread
    getDealy( long, long) // for calculating the time
}

class Timer()
{
    Timer()
    getTime() // get the time value from the SimTimer Class
    delay(int, int) // Handoff Delay Calculation
}

```

The main package is com.net, which has the sub packages as bts, bsc and mu

```

class BaseStaionContellerNetwork
{
    serverPort // for connection with the Server
    clientPort // for communication with the client
    tempServerPort
    clientServerPort
    recClientPort
    createSocket()
    getData()
    sendData(byte[], InetAddress,int)
}

class BscHandleClient
{
    serverPort
    clientPort
    tempServerPort
    clientServerPort
    recClientPort
    Cliadd
    serverSocket
    clientSocket
    file_location
    createSocket()
    getServerData() // to handle the Content server data
    sendServerData(byte[], InetAddress, int)
    getClientData() //to handle the BTS data
    sendClientData(byte[], InetAddress, int)
}

```

class BstHandleClient has the same methods as that of BscHandleClient. The main method is processFile(String), which takes care of all the file transformation for new and handoff connections

```
class MobileUnitFileRequest
{
    clientSocket
    serverPort
    clientServerPort
    tempServerPort
    clientPort
    handoffStartTime
    handoffEndTime
    sendData()
    getData()
    receiveFile()
}
class CsHandleClient(DatagramSocket,String,InetAddress,int)
{
    Cliport
    Cliadd
    handoff
    path
    transferFile(File,int)
    sendData(byte[], InetAddress, int)
    getData()
}
```

#### 4.1.2 Snap Shots

Figure 4.1 shows the creation of BaseStation with the properties, Bst id, Radius, Frequency, MaxBW, Thershold and the BSC id are created.

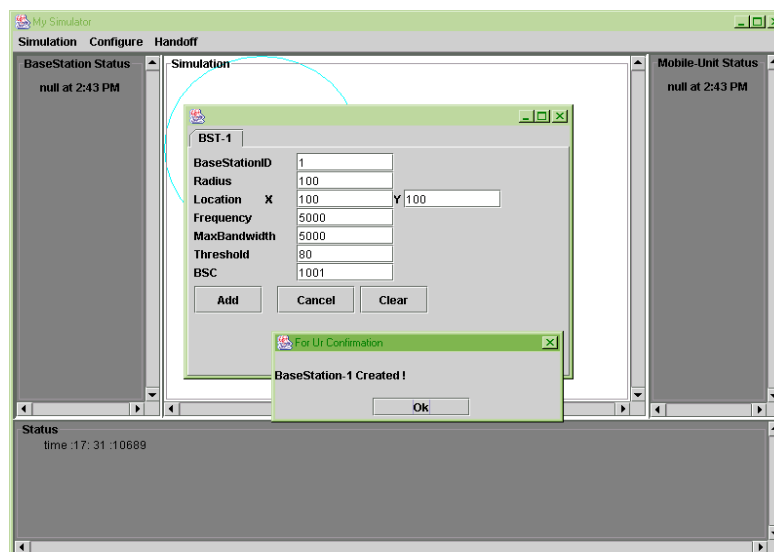
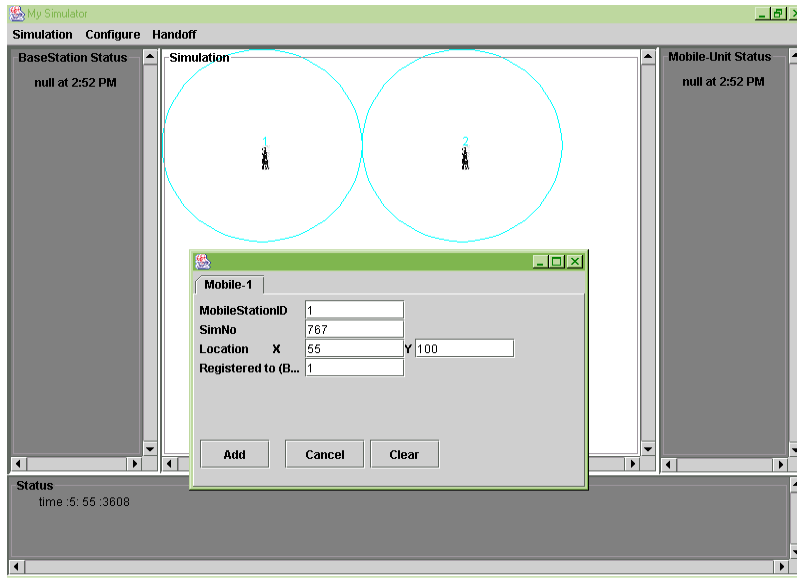


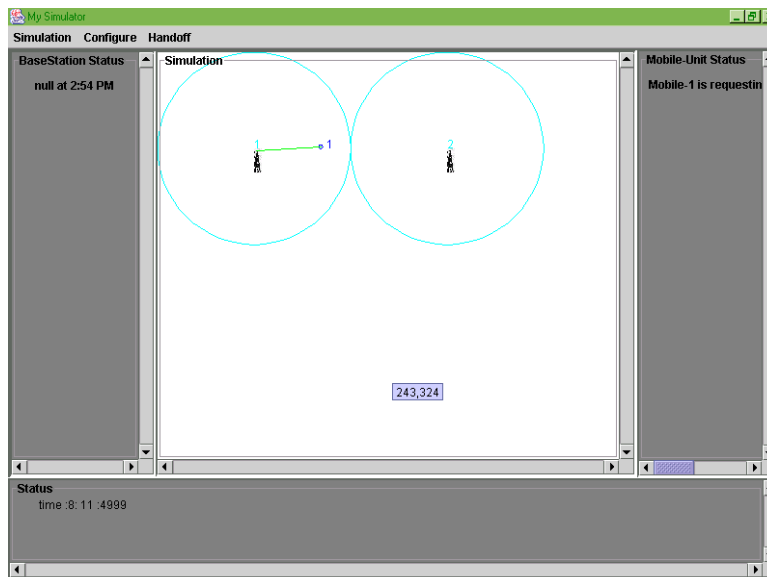
Figure 4.1 - Base Station Creation

Figure 4.2 shows the creation of Mobile, which is registered under BTS 1. The location for x and y-axis along the SIM card number should be given.

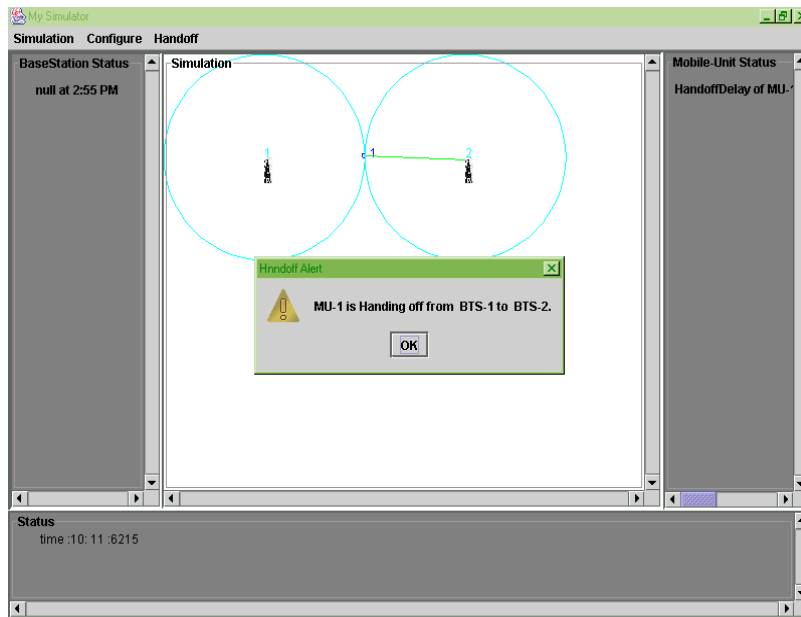


**Figure 4.2 - Mobile Unit Creation**

The mobile unit Request a file to the base station that in turn request the Bsc. The Content server sends the requested file to the base station, which is sent to the mobile unit. Figure 4.3 shows BTS-1 transferring file to the mobile unit.

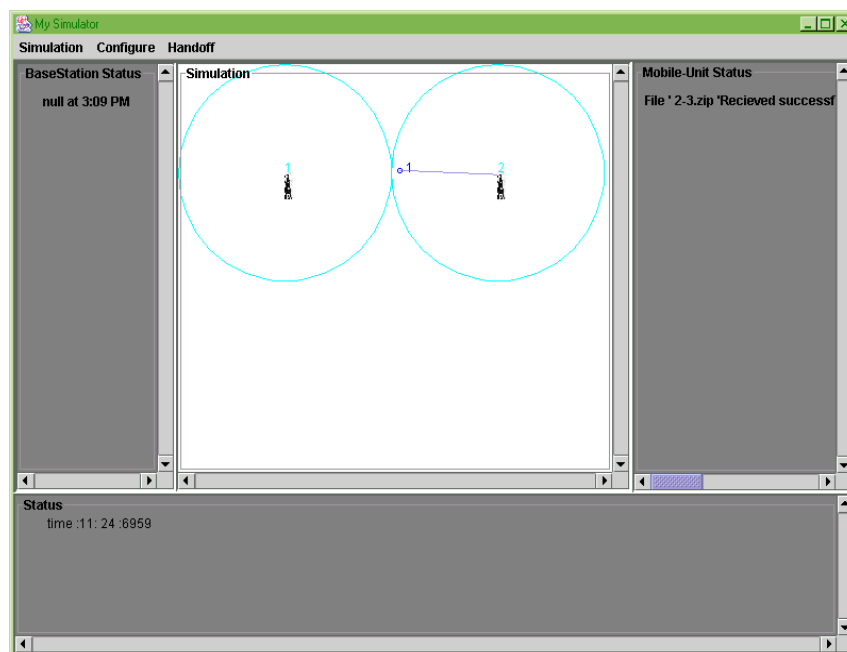


**Figure 4.3 – File Transfer from BTS1**



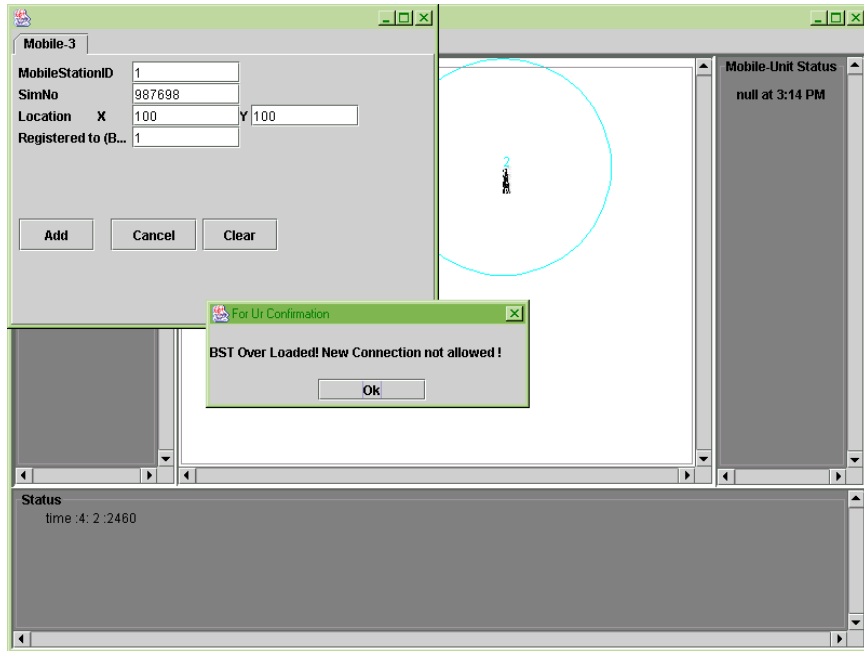
**Figure 4.4 - Handoff from BTS1 to BTS2**

If the mobile unit moves to some other location, the corresponding BTS (or the client, depends on the type of handoff) checks for other BTS which is nearer to the mobile client and passes the state's information to the new BTS. Figure 4.4 shows the handoff from BTS1 to BTS2.



**Figure 4.5 MU received file from BTS-2**

When handoff occurs, BTS1 sends all state's information to the new BTS i.e., BTS2. Now the Base Station 2 continues to send the packets, which is shown in Figure 4.5

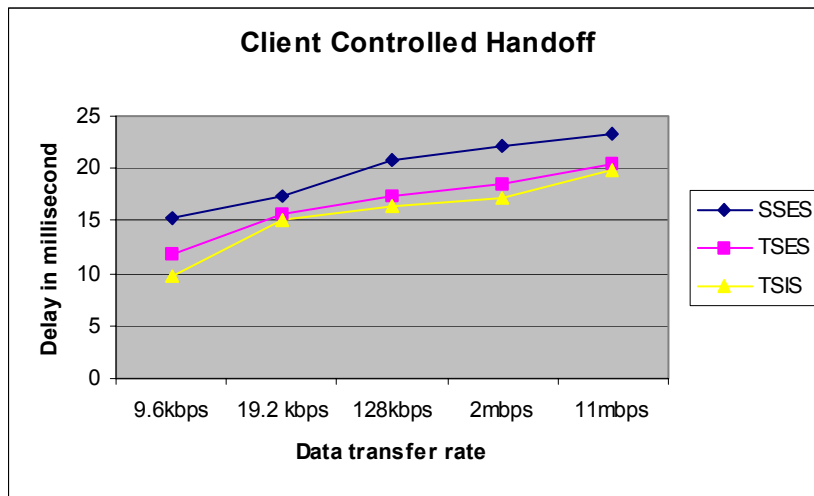


**Figure 4.6 - Content Server Overloading method**

When the Base station is created, it request for the number of mobile nodes that it can hold. This is to check for the load balancing in the base station. When the number of mobile node exceeds the specified capacity during the content server handoff, it does not allow the mobile unit into that particular base station which is shown in Figure 4.6. This is applicable only for the new connection. If it is a handoff connection then the old base station itself sends the packet even when the signal is low.

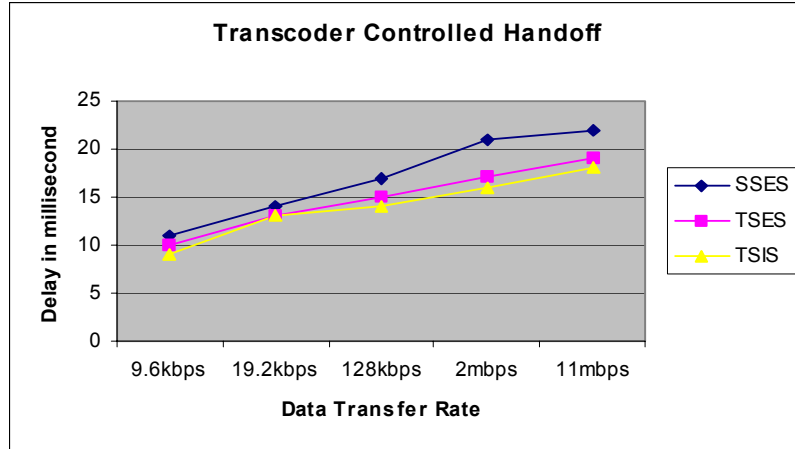
## 4.2 Result

For the implementation, video sequence is streamed between the content server and a client for different handoff approaches. For each approach we record the delay and Packet loss during handoff at the client, and also capture the transcoded output to a file for quality assessment.

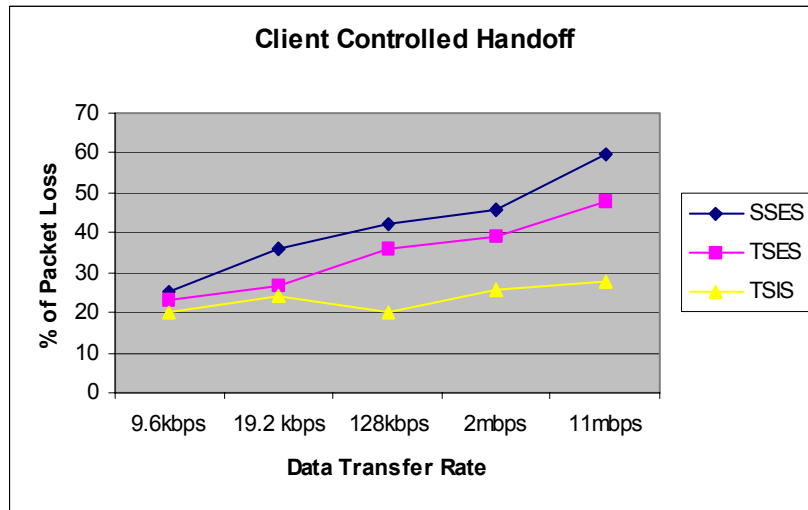


**Figure 4.7 Client Controlled Handoff – Data Transfer rate versus Delay**

The graph shows the difference in data transfer rate for each continuous pair of packets with respect to the delay in milliseconds for the Client Controlled Handoff. This delay should be ideally a constant value for a constant bit-rate stream as produced by the transcoder. However, the Figure 4.7 and 4.8 clearly shows that the SSES scheme introduces a large delay at the hand-off point. Also Figure 4.9 and 4.10 shows that there is more percentage of packet loss during SSES scheme. This leads to a correspondingly degraded video experience at the client. For this set of experiments, the total state data transferred adds up to 11mbps.



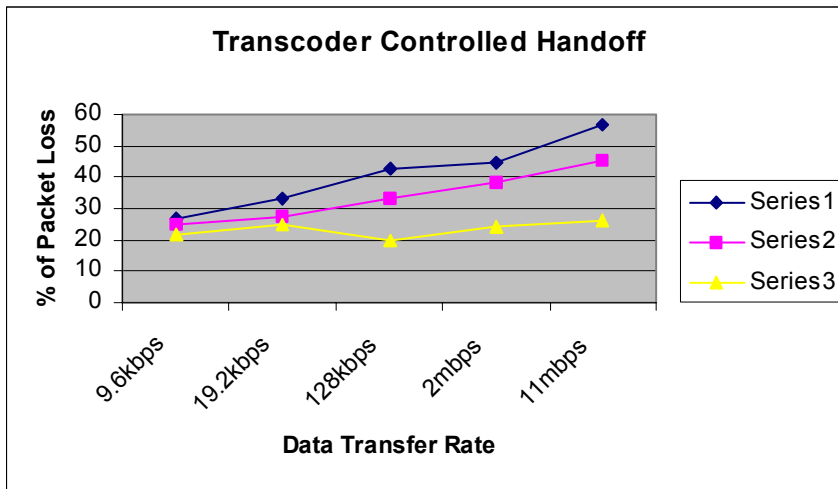
**Figure 4.8 Transcoder Controlled Handoff – Data Transfer rate versus Delay in ms**



**Figure 4.9 Client Controlled Handoff – Data Transfer rate Verses % of Packet Loss**

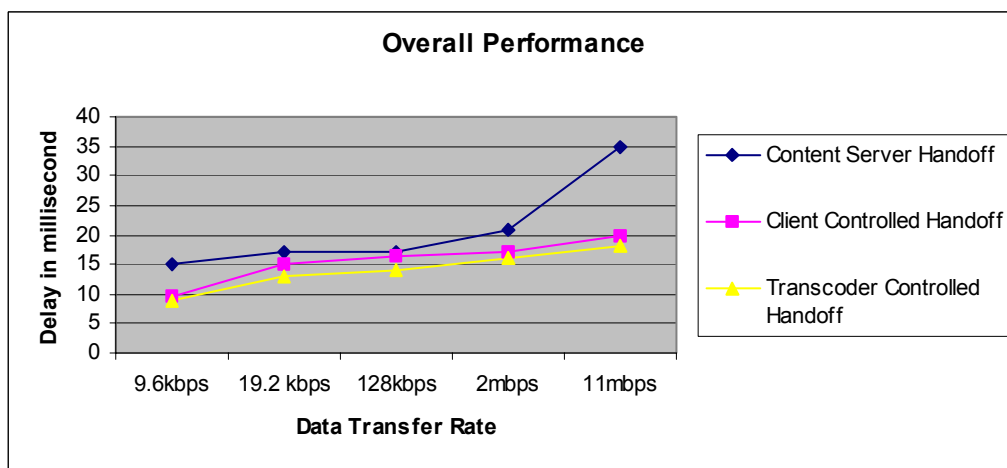
For TSES hand-off, the perceived delay is expected to be smaller regardless of the connection between transcoders or between Client and TS2 since less state information needs to be sent. In addition, the state information is sent in two separated instances. From the Figure 4.7 and 4.8 we can observe that the delay is less than that of the SSES. The percentage of packet loss in TSES is comparatively less than that of SSES.





**Figure 4.10 Transcoder Controlled Handoff - Data Transfer rate verses % of Packet loss**

For TSIS hand-off, in practical cases, either a negative or positive delay is expected. A negative delay indicates that the client may receive packets out of order. In other words, a client buffer is needed or packet dropping is expected. Here the packet loss is more compared to other approaches, which is negligible, the delay is less which is shown in graph, since the transcoder pre-agree with each other and Figure 4.9 and 4.10 shows less packet loss as we are maintaining buffer at the client side.



**Figure 4.11 Overall Performances**

### 4.3 Performance Testing

This testing can be applied to understand this application or to benchmark the performance. This sort of testing is particularly useful to identify performance bottleneck in high use applications.

**Goal:** Analyze the performance of different handoff controlled mechanism

**Procedure:** Calculate the delay for each of the controlled mechanism

**Expected Result:** The delay should be minimum.

#### Test Case 1: Content Server Controlled Handoff

The Content Server initiates handoff. Handoff occurs when the Base station overloaded. Here the number of mobile units for each BTS is given and if more mobile unit enters the base station, handoff occurs. The nearest BTS is calculated and the signal will come from that BTS. Here the delay is more as the information about the Mobile unit, Base station and the VLR, HLR details are stored and updated.

**Average Handoff Delay:** 0 hr:0 min:0 sec:26 ms

#### Test Case 2 : Transcoder Controlled Handoff

The transcoder or the Base station initiates handoff, when the signal is low from the current base station shown in Figure 4.2

##### Test Case 2.1: Single Step Explicit Switch

In this type, when handoff occurs the old base station stops sending packet. It sends the file type, client port, File Pointer to the new base station. Hence the delay is more but less compared to Content Server Handoff.

**Average Handoff Delay:** 0 hr:0 min:0 sec:16 ms

##### Test Case 2.2 : Two Step Explicit Switch

In this type the old base station send the packet even when the handoff message is sent to new BTS. The new BTS make itself ready. When the switch message is sent to new BTS the old base station stop sending the packet. Immediately after getting the switch message the new BTS sends packet to the client.

**Average Handoff Delay:** 0 hr:0 min:0 sec:10ms

### **Test Case 2.3 : Two Step Implicit Switch**

The assumption here is that both the BTS pre-agree with each other about the location of the handoff. Here a threshold value is calculated and compared with the location of the mobile unit.

**Average Handoff Delay:** 0 hr:0 min:0 sec:4 ms

### **Test case 3: Client Controlled Handoff**

In this type of handoff, the mobile unit sends the handoff message to the Base station. The delay graph for different handoff approach is shown in Figure 4.1

#### **Test Case 3.1 : Single Step Explicit Switch**

In SSES, the old Base station stop sending the packet when the Mobile unit send handoff message. Until it sends the Switch message to the new base station, there will be no communication between the base station and the client. Hence the delay will be more compared to transcoders SSES.

**Average Handoff Delay:** 0 hr:0min:0 sec:22 ms

#### **Test Case 3.2 : Two Step Implicit Switch**

In Client controlled TSES handoff, the mobile unit sends the handoff message to the old BTS. Even after getting the message the packet will be sent to the MU from the old BTS. After sending the switch message, the new BTS starts sending the packet. The delay between the old BTS stops sending packet and the new BTS starts sending the packet is calculated.

**Average Handoff Delay:** 0 hr:0min:0 sec:16 ms

#### **Test Case 3.3 : Two Step Implicit Switch**

In this type, the pre-agreement of base stain occurs. When the BTS reaches the location automatically handoff occurs. Hence the delay is comparatively low with other type of client-controlled handoff.

**Average Handoff Delay:** 0 hr:0min:0 sec:6 ms

## CHAPTER 5

### CONCLUSION

An Effective Dynamic Handoff Support for Mobile Media Network provides solution to the problem of hand-off media transcoding sessions, in particular, to provide support to mobile clients. Among the proposed three schemes of different handoff mechanisms, SSES has the least amount of extra transcoding overhead. In addition, this hand-off scenario can sustain an abrupt failure at TS1. The TSES scheme reduces the amount of state transferred, and thus requires a medium amount of communication between the client and transcoding servers. However, the final message latency could still produce a large inter packet gap at the client and affect media quality. The final scheme, TSIS has a larger computational overhead. Minimal state is transferred between the transcoding server, and the resulting media stream is no longer identical to the original stream. This scheme reduces delay and provides good quality to the client. Among the three methods Transcoder Controlled Handoff gives better performance.

Client Controlled handoff has a number of disadvantages. If the transcoders do not talk to each other, then all the information need to transfer has to go a long path from the initial transcoder via the client to the new transcoder. This transmission would have to be over a reliable transport protocol. If the client is a mobile client, it has limited power, and it would be best if its involvement were minimal in the hand-off.

The Content server requires to maintain the state information for all of its transcoding sessions. This is clearly not a very scalable solution, even though a content server has limited content, it has to maintain information for every session. Also, similar to the client-controlled case, the server may have to update its state information from the old transcoder before it can send it to the new transcoder. Finally, this approach implies that transcoding cannot be transparent to the content server.

Hence it is concluded that the Transcoder Controlled Two Step Implicit scheme gives the best performance and reduces the delay and provide good quality.

## REFERENCES

1. ANSI/IEEE Std 830-1998. **IEEE Standard for Software Requirements Specification.**
2. *Sumit Roy, Bo Shen, vijay Sundaram , Raj Kumar*, “ **Applications Level Handoff support for Mobile media Transcoding Sessions**” , HP laboratories, 2002..
3. *Davis Maass*, “ **Handoff of Multimedia Streams**”, 2004
4. *Q.Wei,K.Farkas,P.Mendes,C.Prehofer B.Plattner, N.Nafisi* “**Context-aware Handoff Based on Active Network Technology,**” in DoCoMo Communication Laboratories, 2003
5. *YaYa Wei, Chuang Lin, Raad Raad*, “ **Dynamic Priority Handoff Scheme in Differentiated QoS Wireless Multimedia Networks,**” in Eighth IEEE International Symposium, 2003
6. *Wei-Ying Ma, Bo Shen , Jack Brassil* , “ **Content Services Network : The Architecture and Protocols**”, International Web Content Caching & Distribution Work, 2001.
7. *Roger Karrer and Thomas Gross*, “**Dynamic Handoff of Multimedia Streams,**” in NOSSDAV’01, 2001
8. *S.J.Wee and N.Feamster* “ **An MPEG-2 to H.263 Transcoder**”, in SPIE Voice,Video, and Data Communications Conference 1999
9. *H.Balakrishnan, S.Seshan and R.H. Katz*, “**Improving Reliable Transport and Handoff Performance in Cellular Networks,**” in ACM Wireless Networks Journal, 1995
10. *Parameswaran.R, Krishna.M, Sivalingam and agrwal*, “**Dynamic Resource Allocation Schemes during Handoff for Mobile Multimedia Wireless,**” in IEEE,1999

### Websites

1. The Network Simulator. Ns-2 [www.isi.edu/nsnam/ns](http://www.isi.edu/nsnam/ns)
2. Tcl/tk tutorial [www.hegel.ittc.ukans.edu](http://www.hegel.ittc.ukans.edu)

## **VITA**

Aravinth Kumar Nallusamy was born in the city of Trichirapalli in India, on Jun 3, 1981. He got his Bachelors of Engineering in Computer Science & Engineering from Annamalai University in May, 2002. He joined the Masters of Sciences in Computer Science at the University of New Orleans in 2003.