

1-1-2004

# Homology of Holomorphs of Free Groups

Craig A. Jensen

*University of New Orleans*, [cjensen@uno.edu](mailto:cjensen@uno.edu)

Follow this and additional works at: [http://scholarworks.uno.edu/math\\_facpubs](http://scholarworks.uno.edu/math_facpubs)

 Part of the [Geometry and Topology Commons](#)

---

## Recommended Citation

Jensen, Craig A. Homology of holomorphs of free groups. *J. Algebra* 271 (2004), no. 1, 281–294.

This Article is brought to you for free and open access by the Department of Mathematics at ScholarWorks@UNO. It has been accepted for inclusion in Mathematics Faculty Publications by an authorized administrator of ScholarWorks@UNO. For more information, please contact [scholarworks@uno.edu](mailto:scholarworks@uno.edu).

# Homology of holomorphs of free groups

Craig A. Jensen<sup>1</sup>

*Department of Mathematics, University of New Orleans  
New Orleans, LA 70148, USA  
jensen@math.uno.edu*

---

## Abstract

The holomorph of a free group  $F_n$  is the semidirect product  $F_n \rtimes Aut(F_n)$ . Using the methods of Hatcher and Vogtmann in [10] and [11], we derive stability results and calculate the mod- $p$  homology of these holomorphs for odd primes  $p$  in dimensions 1 and 2, and their rational homology in dimensions 1 through 5. Calculations of the twisted (where  $Aut(F_n)$  acts by first projecting to  $Gl_n(\mathbb{Z})$  and then including in  $Gl_n(\mathbb{Q})$ ) homology  $H_*(Aut(F_n); \mathbb{Q}^n)$  follow in corresponding dimensions.

*Key words:* holomorphs, free groups, automorphism groups, outer space  
*MSC:* Primary 20F32, 20J05; secondary 20F28, 55N91

---

## 1 Introduction

Let  $F_n$  denote the free group on  $n$  letters and let  $Aut(F_n)$  and  $Out(F_n)$  denote the automorphism group and outer automorphism group, respectively, of  $F_n$ . Define the *holomorph* of  $F_n$  to be the semidirect product  $F_n \rtimes Aut(F_n)$ .

When examining the action of  $Aut(F_n)$  on outer space (defined in [9] and [10] by Hatcher and Vogtmann) or the action of the symmetric automorphism group  $\Sigma Aut(F_n)$  on a corresponding space (see Collins in [5] and McCullough and Miller in [15]), holomorphs arise naturally by looking at point stabilizers. Hence (see [13] and [12], where results like these are used) calculating the homology of lower rank holomorphs of  $F_n$  is very useful when calculating the homology of  $Aut(F_n)$  (or related groups, like  $\Sigma Aut(F_n)$ ) in higher ranks.

---

<sup>1</sup> Partially supported by Louisiana Board of Regents Research Competitiveness Subprogram Contract LEQSF-RD-A-39.

Holomorphs of free groups have also been studied recently by Thomas and Velickovic in [18].

Because the Hochschild-Serre spectral sequence of the group extension  $1 \rightarrow F_n \rightarrow F_n \rtimes \text{Aut}(F_n) \rightarrow \text{Aut}(F_n) \rightarrow 1$  has  $E^2$ -page

$$E_{r,s}^2 = H_r(\text{Aut}(F_n); H_s(F_n; M)) \Rightarrow H_{r+s}(F_n \rtimes \text{Aut}(F_n); M),$$

we see that calculating the homology of the holomorph also amounts to calculating the twisted homology of  $\text{Aut}(F_n)$  with coefficients in  $M^n$ . See Dwyer [7] or Borel [2] for results about  $H_*(GL_n(\mathbb{Z}); (\mathbb{Z}/p)^n)$ ,  $H_*(GL_n(\mathbb{Z}); \mathbb{Q}^n)$  which motivated this paper. See also Allison, Ash, and Conrad [1] and Charney [4] for other results in the field.

Let  $F_n$  have free basis  $\{x_1, \dots, x_n\}$ . Define a preferred inclusion  $\iota : F_n \rightarrow F_{n+1}$  on the generators by setting  $\iota(x_i) = x_i$  for all  $1 \leq i \leq n$ . Note that  $\iota$  includes  $F_n$  as a free factor of  $F_{n+1}$ . There is an induced preferred inclusion  $\iota : \text{Aut}(F_n) \rightarrow \text{Aut}(F_{n+1})$  defined by  $\iota(\phi)(x_i) = \phi(x_i)$  if  $1 \leq i \leq n$  and  $\iota(\phi)(x_{n+1}) = x_{n+1}$ . Finally, there induces a preferred inclusion  $\iota : F_n \rtimes \text{Aut}(F_n) \rightarrow F_{n+1} \rtimes \text{Aut}(F_{n+1})$  defined by  $\iota(x, \phi) = (\iota(x), \iota(\phi))$ .

In this paper, we prove the following two results:

**Theorem 1.1 (Homology stability)**

- (1) *The map  $H_i(F_n \rtimes \text{Aut}(F_n); \mathbb{Q}) \rightarrow H_i(F_{n+1} \rtimes \text{Aut}(F_{n+1}); \mathbb{Q})$  induced by preferred inclusion is an isomorphism for  $n > 3i/2$ .*
- (2) *The map  $H_i(F_n \rtimes \text{Aut}(F_n); \mathbb{Z}) \rightarrow H_i(F_{n+1} \rtimes \text{Aut}(F_{n+1}); \mathbb{Z})$  induced by preferred inclusion is an isomorphism for  $n \geq 4i + 2$ .*

**Theorem 1.2 (Low dimensional homology)**

- (1) *If  $p$  is an odd prime,  $1 \leq i \leq 2$  and  $n$  is any positive integer, then*

$$H_i(F_n \rtimes \text{Aut}(F_n); \mathbb{Z}/p) = 0.$$

- (2) *If  $1 \leq i \leq 5$  and  $n$  is any positive integer, then*

$$H_i(F_n \rtimes \text{Aut}(F_n); \mathbb{Q}) = 0,$$

*except when  $i = 4, n = 3$  or  $i = 4, n = 4$  in which case*

$$H_i(F_n \rtimes \text{Aut}(F_n); \mathbb{Q}) = \mathbb{Q}.$$

- (3) *If  $0 \leq i \leq 4$  and  $n$  is any positive integer, then the twisted homology group*

$$H_i(\text{Aut}(F_n); \mathbb{Q}^n) = 0,$$

except when  $i = 3, n = 3$  where

$$H_3(\text{Aut}(F_3); \mathbb{Q}^3) = \mathbb{Q}.$$

Because of the large size of the spaces involved, Maple programs were used to establish Theorem 1.2 (2).

In [10] Hatcher and Vogtmann prove a ‘‘Degree Theorem’’ which they use to derive linear stability ranges for the integral cohomology of  $\text{Aut}(F_n)$  and to show in [11] that for  $1 \leq t \leq 6$  and all  $n \geq 1$ ,

$$H_t(\text{Aut}(F_n); \mathbb{Q}) = \begin{cases} \mathbb{Q} & \text{if } t = n = 4 \\ 0 & \text{otherwise} \end{cases}$$

To prove Theorems 1.1 and 1.2, we borrow the methods of Hatcher and Vogtmann, and details will be omitted when we closely follow their work.

The next section will review outer space and introduce spaces with natural actions by holomorphs of free groups, while the third section argues that the degree theorem holds in the new context of holomorphs of free groups. The fourth section is devoted to proving Theorem 1.1, and the fifth section contains a proof of Theorem 1.2.

The author would like to thank Prof. Vogtmann (his thesis advisor while at Cornell) and Prof. Hatcher for their help through the years. The author would like to thank the referee for many helpful comments which improved the exposition of this paper.

## 2 $\text{Aut}(F_n)$ , outer space, and holomorphs

Let  $(R_n, *)$  be the  $n$ -leafed rose,  $n$  circles wedged together at the basepoint  $*$ . Recall (see [6], [10], and [17]) that the spine  $X_n$  of ‘‘outer space’’ is the realization of a poset of pointed graphs  $(\Gamma, *)$  equipped with *markings* (homotopy equivalences) from the  $n$ -leafed rose. The poset structure derives from forest collapses in  $\Gamma$  and the  $\text{Aut}(F_n)$ -action twists the marking. Let  $Q_n$  be the quotient of  $X_n$  by  $\text{Aut}(F_n)$ . Define  $\mathbb{A}_n$  to be outer space (as opposed to its spine) where the edges in a marked graph have lengths which must sum to 1. Define  $X_{n,k}$ ,  $Q_{n,k}$ , and  $\mathbb{A}_{n,k}$  to be the parts of  $X_n$ ,  $Q_n$ , and  $\mathbb{A}_n$ , respectively, corresponding to graphs of degree less than or equal to  $k$  (see [10].)

Let  $\Theta_m$  be the graph with two vertices and  $m + 1$  edges, each of which goes from one vertex to the other. Let  $\mathcal{Q} \cong \mathbb{Z}/3$  be the subgroup of  $\text{Aut}(F_{n+2})$  given by the  $\mathbb{Z}/3$ -action of rotating the edges of the graph  $\Theta_2$  in  $R_n \vee \Theta_2$  (where the wedge joins the vertex of  $R_n$  with one of the two vertices of  $\Theta_2$  and the resulting vertex is the basepoint of the graph.) In Definition 6.3 of [13],

the space  $\tilde{X}_n$  was defined to be the fixed point subcomplex  $X_{n+2}^{\mathcal{Q}}$  and it was observed that the normalizer

$$N_{Aut(F_{n+2})}(\mathcal{Q}) \cong \Sigma_3 \times (F_n \rtimes Aut(F_n))$$

acts properly on  $X_{n+2}$ . In addition, Definition 6.3 of [13] defines  $\tilde{Q}_n$  to be the quotient of  $\tilde{X}_n$  by  $N_{Aut(F_{n+2})}(\mathcal{Q})$ . Proposition 6.8 of [13] describes the action of  $N_{Aut(F_{n+2})}(\mathcal{Q})$  on  $\tilde{X}_n$  in detail. It is shown that the quotient of  $\tilde{X}_n$  by  $F_n \rtimes Aut(F_n)$  is also  $\tilde{Q}_n$ .

As shown in Proposition 6.4 of [13], the fixed point space  $\tilde{X}_n$  can equivalently be characterized as the realization of the poset of equivalence classes of pairs  $(\alpha, f)$ , where  $\alpha : R_n \rightarrow \Gamma_n$  is a pointed marked graph whose underlying graph  $\Gamma_n$  has a special (possibly valence 2) vertex which is designated as  $\circ$ ,  $\circ$  may equal the basepoint  $*$  of  $\Gamma_n$ , and  $f : I \rightarrow \Gamma_n$  is a homotopy class (rel endpoints) of maps from  $*$  to  $\circ$  in  $\Gamma_n$ . Basically, the extra vertex  $\circ$  encodes that  $\Theta_2$  is attached at the indicated point when translating back to marked graphs of genus  $n + 2$ . Marked graphs  $(\alpha^1, f^1)$  and  $(\alpha^2, f^2)$  are *equivalent* if there is a homeomorphism  $h$  from  $\Gamma_n^1$  to  $\Gamma_n^2$  which sends  $*$  to  $*$ ,  $\circ$  to  $\circ$ , such that

$$(h\alpha^1)_{\#} = (\alpha^2)_{\#} : \pi_1(R_n, *) \rightarrow \pi_1(\Gamma_n^2)$$

and such that the paths

$$hf_1, f_2 : I \rightarrow \Gamma_n^2$$

are homotopic rel endpoints. Moreover, from Remark 6.1 of [13], the quotient space  $\tilde{Q}_n$  can be characterized as the realization of the poset of equivalence classes of pointed graphs  $\Gamma_n$  which have possibly valence 2 special vertex  $\circ$  (which we think of as signifying that a  $\Theta_2$  should be attached to the graph at that point) which may equal the basepoint  $*$ .

As in Definition 6.9 of [13], define  $\tilde{\mathbb{A}}_n$  to be the analog of  $\tilde{X}_n$  where the edges in graphs have lengths which must sum to 1. That is, in addition to having markings from  $\alpha$  and  $f$ , graphs in  $\tilde{\mathbb{A}}_n$  have metrics where each edge has a length and the metric is the induced path metric. We further normalize these metrics by insisting that the sums of the lengths of the edges of a graph in  $\tilde{\mathbb{A}}_n$  must sum to 1.

Corresponding to the preferred inclusion  $Aut(F_n) \rightarrow Aut(F_{n+1})$ , there is an equivariant map of spaces  $X_n \rightarrow X_{n+1}$  obtained by sending the marked graph  $\alpha : R_n \rightarrow \Gamma$  to  $(\alpha, id) : R_n \vee R_1 \rightarrow \Gamma \vee R_1$ . Let  $G_n = F_n \rtimes Aut(F_n)$ . Similarly, the preferred inclusion  $G_n \rightarrow G_{n+1}$  corresponds to a  $G_n$ -equivariant preferred inclusion  $\iota : \tilde{X}_n \rightarrow \tilde{X}_{n+1}$  given by sending the pair  $(\alpha, f)$  to  $((\alpha, id), f)$ .

### 3 The modified degree theorem

Our goal is to show that Hatcher and Vogtmann’s Degree Theorem in [10] also applies to holomorphs of free groups and the space  $\tilde{X}_n$ . This section is written to convince those already familiar with [10] that their proof carries over into this new context, and is not meant to be read independently.

As in the case of  $\mathbb{A}_n$ , graphs in  $\tilde{\mathbb{A}}_n$  come equipped with a “height function” measuring distance to the basepoint. Given a particular point  $v$  in such a graph, we can take a small neighborhood of it and obtain a star graph consisting of  $v$  and the germs of all edges attached to  $v$  in the graph. Some of these germs are *ascending* because points on them have height greater than that of  $v$  (equivalently, points on that germ are farther away from the basepoint in the graph.) Other germs are *descending* because points on them are closer to the basepoint.

Define the *degree* of a marked graph

$$(\alpha, f) : R_n \amalg I \rightarrow \Gamma_n$$

or, equivalently, the degree of the underlying graph  $\Gamma_n$  of the marked graph, to be

$$\deg(\alpha, f) = \deg(\Gamma_n) = \sum_{v \neq * } ||v|| - 2,$$

where the sum is over all vertices of  $\Gamma_n$  except the basepoint, and where the *augmented valence*  $||v||$  of a vertex  $v \neq \circ$  is the number of oriented edges starting at  $v$  (i.e., the valence  $|v|$  of  $v$ ). The *augmented valence* of the vertex  $\circ$  is defined to be one plus the number of oriented edges starting at  $\circ$ , or  $|\circ| + 1$ . This definition is similar to the one given in [10], but the intuition (which we do not attempt to make precise) is that we treat the vertex  $\circ$  as if it signifies that an ascending germ of an extra edge is attached to that vertex. Throughout this section, our modified definitions of degree, split degree, canonical splitting, etc., will be motivated by this notion of thinking that the vertex  $\circ$  denotes the germ of another edge entering that vertex.

Let  $\tilde{X}_{n,k}$ ,  $\tilde{Q}_{n,k}$ , and  $\tilde{\mathbb{A}}_{n,k}$  be the subspaces of  $\tilde{X}_n$ ,  $\tilde{Q}_n$ , and  $\tilde{\mathbb{A}}_n$ , respectively, where only marked graphs of degree at most  $k$  are considered. Define  $D_k$  to be a  $k$ -dimensional disk. We want to prove the following analog of the degree theorem, Theorem 3.1 of [10]:

**Theorem 3.1** *A piecewise linear map  $f_0 : D_k \rightarrow \tilde{\mathbb{A}}_n$  is homotopic to a map  $f_1 : D_k \rightarrow \tilde{\mathbb{A}}_{n,k}$  by a homotopy  $f_t$  during which degree decreases monotonically, i.e., if  $t_1 < t_2$  then  $\deg(f_{t_1}(s)) \geq \deg(f_{t_2}(s))$  for all  $s \in D_k$ .*

As in [10], the immediate corollary is

**Corollary 3.2** *The pair  $(\tilde{\mathbb{A}}_n, \tilde{\mathbb{A}}_{n,k})$  is  $k$ -connected.*

In [14], we show that  $\tilde{\mathbb{A}}_n$  is contractible, so that Corollary 3.2 implies that  $\tilde{\mathbb{A}}_{n,k}$  is  $(k - 1)$ -connected.

Hatcher and Vogtmann prove the degree theorem by using various homotopies to deform the underlying graphs of marked graphs

$$\alpha : R_n \rightarrow \Gamma_n.$$

We will use these same homotopies to deform the marked graphs

$$(\alpha, f) : R_n \amalg I \rightarrow \Gamma_n$$

that appear in the context of  $\tilde{\mathbb{A}}_n$ . In a remark following “Stage 1: Simplifying the critical point” in [10], Hatcher and Vogtmann mention that it is obvious where their homotopies of the underlying graph  $\Gamma_n$  send the basepoint  $*$  and the marking  $\alpha$ . Our task is to decide where these homotopies send the extra point  $\circ$  on the graph. It will then be clear where the homotopies send the path  $f$  from  $*$  to  $\circ$  in the graph  $\Gamma_n$ .

A point in the graph is a *critical point* if in a small neighborhood of that point there is more than one descending germ.

A few notes are in order about specific parts of the paper by Hatcher and Vogtmann and how these should be modified:

- (1) Canonical splittings. A procedure called “canonical splitting” is defined in [10] to decrease the degrees of graphs in a canonical way. A canonical splitting should move  $\circ$  down to the next critical point or the basepoint, provided  $\circ$  is not already a critical point. See Figure 1 for examples.

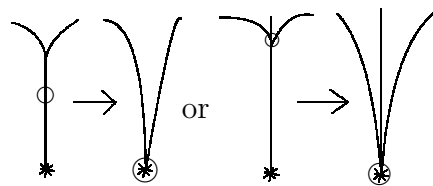

Fig. 1. Canonical splittings

- (2) Sliding  $\epsilon$ -cones. We can also perturb the graph slightly and slide  $\circ$  downward off of a critical point.
- (3) Codimension. As in [10], the *codimension* of a point on the graph is one less than the number of downward directions from that point. The *codimension* of a graph is the sum of the codimensions of its critical points.
- (4) Lemma 4.1 needs no modification.

- (5) Lemma 4.2. During the homotopies used in Lemma 4.2, only the lengths of the edges of the underlying graph  $\Gamma_n$  are perturbed. The combinatorial structure of the graph is not changed at all. Hence it is clear where  $\circ$  and the path  $f$  from  $*$  to  $\circ$  are sent during these homotopies.
- (6) Complexity. As before, we think of  $\circ$  as having an ascending germ attached there. Hatcher and Vogtmann defined a connecting path as a downward path from one critical point to another. We modify this by saying that the extra germ attached at  $\circ$  counts as the beginning of a downward path that came from a critical point lying above. With this convention, the complexity  $c_s$  (respectively,  $e_s$ ) is defined as the number of connecting paths (respectively, without critical points in their interiors) in the graph. See Figure 2.

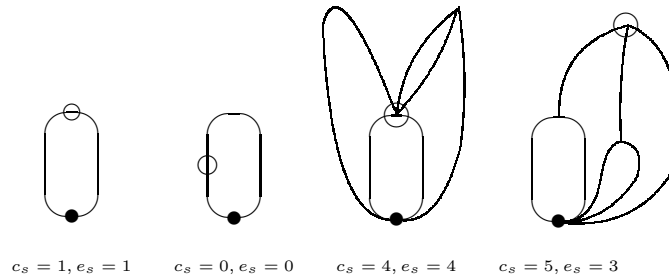

Fig. 2. Complexity examples with  $\circ$

Using this definition of complexity in place of that given in [10], the section “canonical splitting and extension to a neighborhood” of [10] remains valid as written. For the section “reducing complexity by sliding in the  $\epsilon$ -cones”, consider  $\circ$  as giving an attaching point  $\alpha_j$  of a branch  $\beta_j$ . Now argue as directed in [10].

Using the above guidelines, the proof of Theorem 3.1 follows from the work of Hatcher and Vogtmann in [10].

## 4 Stability results

The following lemma is a restatement of Lemma 5.2 of [10].

**Lemma 4.1** *Let  $\Gamma$  be the underlying graph of a marked graph in  $\tilde{X}_{n,k}$ .*

- (1) *If  $k < n/2$ , then  $\Gamma$  has an  $R_1$  wedge summand.*
- (2) *If  $k < 2n/3$ , then  $\Gamma$  has an  $R_1$  or  $\Theta_2$  wedge summand.*
- (3) *If  $k < n - 1$ , then  $\Gamma - \{*\}$  is disconnected.*



**Proof.** Without loss of generality, assume that  $\Gamma$  has degree  $k$ , that all vertices not equal to  $*$  or  $\circ$  are trivalent, and that  $\circ$  is bivalent if it is not equal to  $*$ . Define  $\Lambda$  to be the full subgraph of  $\Gamma$  spanned by all non-basepoint vertices. Let  $E$  and  $V = k$  be the number of edges and vertices, respectively, of  $\Lambda$ .

If  $\Gamma$  has no  $R_1$  wedge summand at  $*$ , then the valence  $|*|$  is  $2n - k$  if  $* = \circ$  (respectively  $2n - k - 1$  if  $* \neq \circ$ ) and so  $\chi(\Gamma) = 1 - n$  is  $1 - 2n + 2k - E$  (resp.  $-2n + 2k - E$ ); therefore,  $n$  is  $2k - E$  (resp.  $2k - E - 1$ ) and (1) follows. If  $k < 2n/3$ , then we can assume  $E$  is less than  $k/2$  (resp.  $k/2 - 1$ ), resulting in an isolated vertex  $v$  of  $\Lambda$  not equal to  $\circ$  and establishing (2). If  $k < n - 1$ , similar arguments show that  $\chi(\Lambda)$  is greater than 1 (resp. 2) so that  $\Lambda$  is disconnected.  $\square$

Note that Theorem 1.1 (1) follows from Lemma 4.1 in the same way that Proposition 5.5 of [10] follows from Lemma 5.2 of [10]. The proof of integral homology stability contained in [10] does not appear, however, to apply to the case of holomorphs. We try a different approach here.

**Proof of Theorem 1.1 (2).** Recall that  $G_n = F_n \times \text{Aut}(F_n)$ . Fix a positive integer  $i$  and assume  $n \geq 4i + 2$ . Let  $C \rightarrow \mathbb{Z}$  and  $C' \rightarrow \mathbb{Z}$  be the augmented cellular chain complexes of  $\tilde{X}_{n,i+1}$  and  $\tilde{X}_{n+1,i+1}$ , respectively. There is a chain map  $\iota : C \rightarrow C'$  induced by the preferred inclusion  $\iota : \tilde{X}_{n,i+1} \rightarrow \tilde{X}_{n+1,i+1}$ . The augmented complexes  $C \rightarrow \mathbb{Z}$  and  $C' \rightarrow \mathbb{Z}$  are exact in dimensions less than or equal to  $i$  by Corollary 3.2. Let  $F \rightarrow \mathbb{Z}$  be a free resolution of  $\mathbb{Z}$  as a  $\mathbb{Z}G_{n+1}$ -module. Since  $G_n$  is contained in  $G_{n+1}$ ,  $F \rightarrow \mathbb{Z}$  is also a free resolution of  $\mathbb{Z}$  as a  $\mathbb{Z}G_n$ -module. Let  $\phi$  be the composition

$$F \otimes_{\mathbb{Z}G_n} C \xrightarrow{1 \otimes \iota} F \otimes_{\mathbb{Z}G_n} C' \xrightarrow{p} F \otimes_{\mathbb{Z}G_{n+1}} C'.$$

The morphism  $\phi$  of double complexes induces morphisms of the spectral sequences corresponding to the double complexes. Taking vertical filtrations of  $F \otimes_{\mathbb{Z}G_n} C$  and  $F \otimes_{\mathbb{Z}G_{n+1}} C'$  (see [3] page 173), we obtain spectral sequences where the  $E_{r,s}^2$  pages converge to  $H_{r+s}(G_n; \mathbb{Z})$  and  $H_{r+s}(G_{n+1}; \mathbb{Z})$ , respectively, for  $r + s \leq i$ . Taking horizontal filtrations, we have spectral sequences with

$$E_{r,s}^1 = \prod_{\sigma \in \tilde{Q}_{n,i+1}^r} H_s(\text{stab}_{G_n}(\sigma); \mathbb{Z}) \Rightarrow H_{r+s}(G_n; \mathbb{Z}), \text{ for } r + s \leq i,$$

and

$$\bar{E}_{r,s}^1 = \prod_{\sigma \in \tilde{Q}_{n+1,i+1}^r} H_s(\text{stab}_{G_{n+1}}(\sigma); \mathbb{Z}) \Rightarrow H_{r+s}(G_{n+1}; \mathbb{Z}), \text{ for } r + s \leq i,$$

where  $\tilde{Q}_{n,i+1}^r$  and  $\tilde{Q}_{n+1,i+1}^r$  are the  $r$ -cells in  $\tilde{Q}_{n,i+1}$  and  $\tilde{Q}_{n+1,i+1}$ , respectively. Since  $n \geq 4i + 2$ , Lemma 4.1 (1) yields that every marked graph in  $\tilde{Q}_{n,i+1}$  (re-

spectively  $\tilde{Q}_{n+1,i+1}$ ) has at least  $2i$  (respectively  $2i+1$ ) loops at the basepoint. This yields a homeomorphism  $f : \tilde{Q}_{n,i+1} \rightarrow \tilde{Q}_{n+1,i+1}$  defined on graphs by adding a loop at the basepoint. Moreover, if  $\sigma \in \tilde{Q}_{n,i+1}^r$ , we can represent  $\sigma$  as a pair  $(\Gamma, F)$ , where  $F$  is some chain of forest collapses in  $\Gamma$ . Write  $\Gamma = \Gamma_0 \vee R_j$ , where  $\Gamma_0$  has no loops at the basepoint and  $j \geq 2i$ . Let  $G$  be the group of graph isomorphisms of  $\Gamma_0$  respecting the chain  $F$  of forests (see [17].) Hence  $f(\sigma) = (\Gamma_0 \vee R_{j+1}, F)$ ,  $\text{stab}_{G_n}(\sigma) = G \times \Sigma_j$ , and  $\text{stab}_{G_{n+1}}(\sigma) = G \times \Sigma_{j+1}$ . From the stability result for the homology of the symmetric groups in Corollary 6.7 of [16] and the Künneth Formula, we see that the induced map

$$H_s(\text{stab}_{G_n}(\sigma); \mathbb{Z}) \rightarrow H_s(\text{stab}_{G_{n+1}}(\sigma); \mathbb{Z})$$

is an isomorphism for  $s \leq i$ . Thus  $\phi_* : E_{r,s}^1 \rightarrow \bar{E}_{r,s}^1$  is an isomorphism for  $r + s \leq i$  and (cf. Proposition 2.6 from Chapter VII of [3])  $\phi_* : H_k(G_n; \mathbb{Z}) \rightarrow H_k(G_{n+1}; \mathbb{Z})$  is an isomorphism for  $k \leq i$ .  $\square$

## 5 Low dimensional homology groups

As in Hatcher-Vogtmann [11], the degree theorem, Theorem 3.1, can be used to prove Theorem 1.2 and calculate the homology  $F_n \rtimes \text{Aut}(F_n)$  in low dimensions.

**Lemma 5.1** *If  $n, i$  are positive integers, then*

$$H_i(F_n \rtimes \text{Aut}(F_n); \mathbb{Q}) \cong H_i(\tilde{Q}_{n,i+1}; \mathbb{Q})$$

and

$$H_{i+1}(\tilde{Q}_{n,i+1}, \tilde{Q}_{n,i}; \mathbb{Q}) \rightarrow H_i(\tilde{Q}_{n,i}; \mathbb{Q}) \rightarrow H_i(\tilde{Q}_{n,i+1}; \mathbb{Q}) \rightarrow 0$$

is exact.

**Proof.** That  $H_i(G_n; \mathbb{Q}) \cong H_i(\tilde{Q}_{n,i+1}; \mathbb{Q})$  follows from considering the equivariant homology spectral sequence for  $G_n$  acting on  $\tilde{Q}_{n,i+1}$  (cf. [3]), noting that it is concentrated in only one row because we have  $\mathbb{Q}$  coefficients and stabilizers are finite, and since  $\tilde{Q}_{n,i+1}$  is  $i$ -connected. For similar reasons, we have that both  $H_{i+1}(\tilde{Q}_n, \tilde{Q}_{n,i+1}; \mathbb{Q})$  and  $H_i(\tilde{Q}_n, \tilde{Q}_{n,i}; \mathbb{Q})$  are zero so that the long exact sequence of the triple  $(\tilde{Q}_n, \tilde{Q}_{n,i+1}, \tilde{Q}_{n,i})$  gives that  $H_i(\tilde{Q}_{n,i+1}, \tilde{Q}_{n,i}; \mathbb{Q}) = 0$ . The lemma follows by considering the long exact sequence of the pair  $(\tilde{Q}_{n,i+1}, \tilde{Q}_{n,i})$ .  $\square$

A corresponding result for  $\mathbb{Z}/p$  coefficients is:

**Lemma 5.2** *Let  $p$  be an odd prime and  $n \geq 1$ . Then*

- (1)  $H_1(F_n \rtimes \text{Aut}(F_n); \mathbb{Z}/p) = 0$ .
- (2)  $H_2(F_n \rtimes \text{Aut}(F_n); \mathbb{Z}/p) \cong H_2(\tilde{Q}_{n,3}; \mathbb{Z}/p)$ .
- (3)  $H_3(\tilde{Q}_{n,3}, \tilde{Q}_{n,2}; \mathbb{Z}/p) \rightarrow H_2(\tilde{Q}_{n,2}; \mathbb{Z}/p) \rightarrow H_2(\tilde{Q}_{n,3}; \mathbb{Z}/p) \rightarrow 0$  is exact.

**Proof.** From the five term exact sequence of the group extension corresponding to the semidirect product  $G_n$  (cf. page 171 of [3]),  $H_1(F_n; \mathbb{Z})_{\text{Aut}(F_n)} \rightarrow H_1(G_n; \mathbb{Z}) \rightarrow H_1(\text{Aut}(F_n); \mathbb{Z})$  is exact. By [9],  $H_1(\text{Aut}(F_n); \mathbb{Z}) = \mathbb{Z}/2$ . Let  $\xi_n \in \text{Aut}(F_n)$  be the automorphism (cf. [8]) sending each generator to its inverse. Then  $\xi_n$  sends  $(x_1, \dots, x_n) \in \mathbb{Z} \oplus \dots \oplus \mathbb{Z} \cong H_1(\text{Aut}(F_n); \mathbb{Z})$  to  $(-x_1, \dots, -x_n)$ . Hence  $H_1(F_n; \mathbb{Z})_{\text{Aut}(F_n)}$  is all 2-torsion. Thus  $H_1(G_n; \mathbb{Z})$  is 2-torsion and  $H_1(G_n; \mathbb{Z}/p) = 0$ .

To show  $H_2(G_n; \mathbb{Z}/p) \cong H_2(\tilde{Q}_{n,3}; \mathbb{Z}/p)$  consider the equivariant homology spectral sequence for  $G_n$  acting on  $\tilde{Q}_{n,3}$ .

If  $p \geq 7$ , and a graph  $\Gamma_n$  in  $\tilde{Q}_{n,3}$  has  $p$ -symmetry, the symmetry comes from permuting petals attached at the basepoint and leaving the rest of the graph fixed. This is because if an edge  $e$  with endpoints  $v$  and  $w$ ,  $w \neq *$ , is permuted nontrivially by the  $p$ -action, then the  $p$ -orbit of  $e$  forces the graph to have degree at least  $p - 2$  (if  $w$  is fixed by the action) or  $p$  (if  $w$  is not fixed.) In any case, the degree would be too large. So all  $p$ -symmetry in  $\tilde{Q}_{n,3}$  comes from the rose, in the sense that a graph with  $p$ -symmetry consists of a rose graph  $R_s$ ,  $s \in \{n - 6, n - 5, \dots, n\}$ , wedged to some other graph fixed by  $p$ . Such  $p$ -symmetry results in stabilizers with comhomology the same as that of symmetric groups. The homology of these (see [16]) vanishes in dimensions 1 and 2. Since  $H_t(\text{stab}_{\Gamma_n}(R_s); \mathbb{Z}/p) = H_t(\Sigma_s; \mathbb{Z}/p) = 0$  for  $t = 1, 2$ , the result holds by a standard restriction-transfer argument in group cohomology which implies that we need only be concerned with simplices with  $p$ -symmetry.

If  $p = 3, 5$ , there are more simplices with  $p$ -symmetry in  $\tilde{Q}_{n,3}$ , such as graphs based on  $\theta$ -graphs (the most complicated of these in the case  $p = 3$  being three  $\Theta_2$  graphs wedged together at  $* = \circ$  with a symmetry group of  $(\Sigma_3 \times \Sigma_3 \times \Sigma_3) \rtimes \Sigma_3$ .) The homology of their stabilizers still vanishes in dimensions 1 and 2, however, establishing this part of the lemma.

Mimic the proof of Lemma 5.1 to obtain the exactness of

$$H_3(\tilde{Q}_{n,3}, \tilde{Q}_{n,2}; \mathbb{Z}/p) \rightarrow H_2(\tilde{Q}_{n,2}; \mathbb{Z}/p) \rightarrow H_2(\tilde{Q}_{n,3}; \mathbb{Z}/p) \rightarrow 0.$$

□

Let  $p$  be an odd prime and  $n$  be a positive integer. From the above lemma, to prove Theorem 1.2 (1), it suffices to show that  $H_2(\tilde{Q}_{n,3}; \mathbb{Z}/p) = 0$ . Because

part (2) of the theorem will be established purely by computer program, we illustrate this in some detail to provide at least one concrete example.

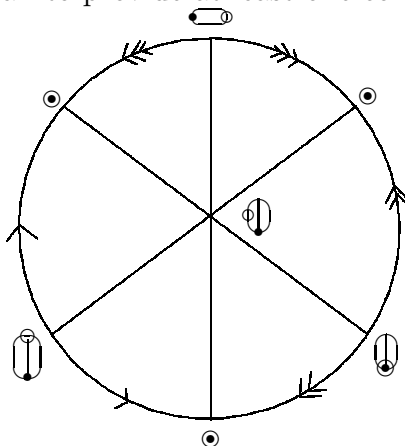

Fig. 3. The 2-sphere in  $\tilde{Q}_{n,2}$

As a notational device, when drawing a graph  $\Gamma_n$  omit any loops at the basepoint. An example of a 2-sphere in  $\tilde{Q}_{n,2}$  is illustrated above in Figure 3. In the figure, a filled dot represents the basepoint  $*$  and a hollow dot represents the other distinguished point  $\circ$ .

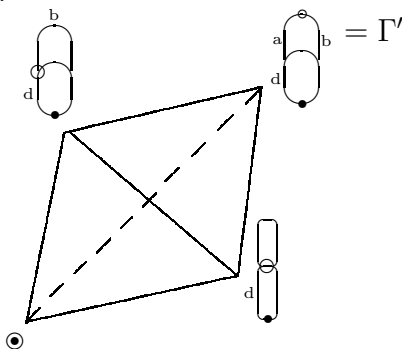

Fig. 4. One of 6 3-simplices making up the sample cube.

Following [11], we make use of a cubical structure on some open cells in  $\tilde{Q}_{n,i}$  and the notion of plusfaces and minusfaces for this cubical structure and more generally for the simplicial structure. Figures 4 and 5 provide an example in the 3-dimensional complex  $\tilde{Q}_{n,3}$ : Consider a graph  $\Gamma'$  with 4 vertices:  $*$ ,  $\circ$ , and two other valence 3 vertices  $x$  and  $y$ . The graph  $\Gamma'$  has 5 (unoriented) edges. The edge  $a$  connects  $\circ$  and  $x$ ,  $b$  connects  $\circ$  and  $y$ ,  $c$  connects  $x$  and  $y$ ,  $d$  connects  $*$  and  $x$ , and  $e$  connects  $*$  and  $y$ . The graph  $\Gamma'$  is the one shown in the upper right corners of Figures 4 and 5. Define a forest  $F$  in  $\Gamma'$  by  $F = \{a, b, d\}$ . There are 6 3-simplices in  $\tilde{Q}_{n,2}$  corresponding to the forest  $F$ . Each corresponds to some collapse of the edges in  $F$  in a particular order. For example, the 3-simplex in Figure 4 comes from collapsing first  $a$ , then  $b$ , and then  $d$ . These 6 3-simplices all fit together into the cube in Figure 5.

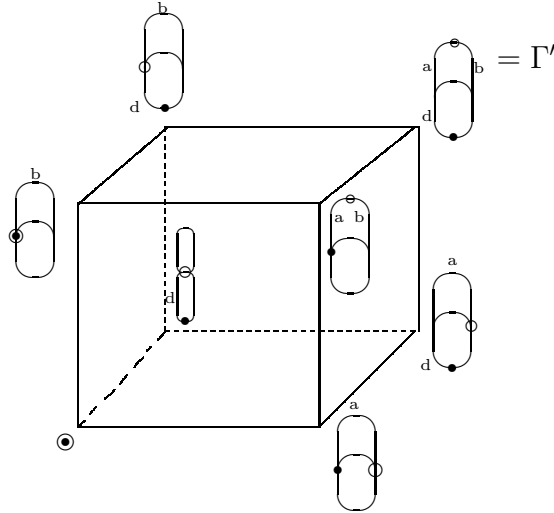

Fig. 5. A sample cube in  $\tilde{Q}_{n,3}$

Note that the cube and simplex pictured above each have one vertex which is maximal (in the poset sense); namely, the one given by  $\Gamma'$ . A face of the cube or simplex is called a *plusface* if it is adjacent to this maximal vertex and a *minusface* otherwise. The *diagonal* of a cube is the edge (present only in the simplicial structure and not in the cubical one) joining the poset-maximal and the poset-minimal vertices of the cube.

The subset  $F$  of edges of  $\Gamma'$  gives the interior of a 3-dimensional cube as pictured in Figure 5 because all of the 6 3-simplices that form the cube are distinct. This in turn is true because no nontrivial graph automorphism of  $\Gamma'$  takes the forest  $F$  to itself. Parts of the boundary of the cube, however, are identified. For example, the plusface corresponding to  $\{a, b\}$  (the face in back in Figure 5) “folds over” along its diagonal so that the square forming the plusface is glued together to form just one 2-simplex, a triangle. That is, the square is decomposed into two triangles attached along a diagonal edge, and in the quotient the two triangles are identified. The other codimension 1 faces (the two other plusfaces and the three other minusfaces) of the cube are squares, and not identified into triangles.

In general, suppose we have a graph  $\Gamma$  which has degree 3 and a forest  $F = \{a, b, c\}$  in  $\Gamma$ . Then the pair  $(\Gamma, F)$  will give a cube in  $\tilde{Q}_n$  if no nontrivial graph automorphism of  $\Gamma$  sends  $F$  to itself. Note that if this is the case, then even though  $(\Gamma, F)$  gives a cube, its faces might be identified or glued to each other in various ways. This can happen with both the plusfaces and the minusfaces. For example, say  $\hat{\Gamma}$  is the graph obtained from  $\Gamma$  by collapsing the edge  $a$ . If a nontrivial graph automorphism of  $\hat{\Gamma}$  switches  $b$  and  $c$ , the minusface of the cube corresponding to  $\hat{\Gamma}$  is glued to itself along a diagonal and is not a square but a 2-simplex or triangle.

**Proposition 5.3** *If  $n = 1$  then  $\tilde{Q}_{n,2}$  is contractible. Otherwise,  $\tilde{Q}_{n,2}$  deformation retracts to the 2-sphere pictured in Figure 3.*

**Proof.** The case  $n = 1$  is left to the reader. Figure 6 lists all graphs which give maximal vertices.

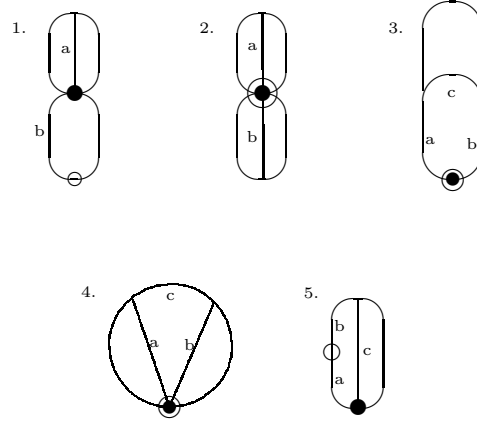

Fig. 6. Graphs giving 2-simplices

Define the deformation retraction onto the 2-sphere by collapsing away from the simplices given by the above graphs (numbered 1 - 5) as follows:

- (1) This graph only has one maximal subforest  $\{a, b\}$  so that the corresponding square (i.e., two 2-simplices that join together to form a square) has free plusfaces. Hence we can collapse this square away.
- (2) This graph also only has one maximal subforest  $\{a, b\}$  and moreover there is an automorphism of the graph that switches  $a$  and  $b$ . This graph just contributes one 2-simplex, the diagonal of which is automatically a free plusface.
- (3) The 2-simplex corresponding to  $\{a, b\}$  has a free diagonal plusface and so can be removed. In addition, the square corresponding to  $\{a, c\}$  has free plusface  $c$ .
- (4) Use exactly the same argument as that for graph 3. in Figure 6.
- (5) The three squares that this graph contributes join together to form the 2-sphere in Figure 3.

□

**Proof. [of Theorem 1.2 (1).]** From Lemma 5.2 and Proposition 5.3, we must find an explicit element in  $H_3(\tilde{Q}_{n,3}, \tilde{Q}_{n,2}; \mathbb{Z}/p)$  which maps onto the generator of  $H_2(\tilde{Q}_{n,2}; \mathbb{Z}/p) = \mathbb{Z}/p$ . The graph  $\Gamma'$  from Figure 5 will be used to construct the relative cycle. Basically, the cycle is formed by joining together the cubes corresponding to the subforests  $\{a, b, d\}$ ,  $\{a, c, d\}$ , and  $\{a, c, e\}$ .

The plusface corresponding to  $\{a, b\}$  of  $\{a, b, d\}$  folds back onto itself along its diagonal and so it is not free. The plusface  $\{a, d\}$  of  $\{a, b, d\}$  connects up with the plusface  $\{a, d\}$  of  $\{a, c, d\}$ . The remaining plusface  $\{b, d\}$  of  $\{a, b, d\}$  joins up with the plusface  $\{a, e\}$  of  $\{a, c, e\}$ . Moreover, the plusface  $\{a, c\}$  of  $\{a, c, d\}$  joins up with the plusface  $\{a, c\}$  of  $\{a, c, e\}$ . Finally, the last remaining plusface  $\{c, d\}$  of  $\{a, c, d\}$  connects with the last remaining plusface  $\{c, e\}$  of  $\{a, c, e\}$ .

The minusface obtained by collapsing  $a$  in  $\{a, b, d\}$  is the same as that obtained by collapsing  $a$  in  $\{a, c, d\}$ . The one obtained by collapsing  $b$  in  $\{a, b, d\}$  is the same as what we get if we collapse  $a$  in  $\{a, c, e\}$ . The remaining minusface of  $\{a, b, d\}$  from collapsing  $d$  is one of the three squares pictured in Figure 3 and corresponds to the subforest  $\{a, b\}$  of graph 5. of Figure 6. Following the same logic, we see that the minusface of  $\{a, c, d\}$  corresponding to collapsing the edge  $c$ , is the same as that of  $\{a, c, e\}$  obtained by collapsing  $c$ . The square  $\{a, c\}$  of the graph 5. of Figure 6 is now seen to be the remaining minusface acquired from  $\{a, c, d\}$  by collapsing  $d$ . Similarly, the square  $\{b, c\}$  of the graph 5. of Figure 6 is the remaining minusface of  $\{a, c, e\}$  which we get if we collapse the edge  $e$ .

In summary, the cubes  $\{a, c, d\}$  and  $\{a, c, e\}$  glue together to form a solid 3-ball along the topological 2-disk formed by the union of the plusfaces  $\{c, d\}$  and  $\{a, c\}$  of  $\{a, c, d\}$  and the minusface of  $\{a, c, d\}$  given by collapsing  $c$ . This solid ball is in turn glued to the ball corresponding to the cube  $\{a, b, d\}$  along the topological 2-disk formed by the union of the plusfaces  $\{a, d\}$  and  $\{b, d\}$  of  $\{a, b, d\}$  and the minusfaces of  $\{a, b, d\}$  corresponding to collapsing  $\{a\}$  and  $\{b\}$ . Note that this latter surface is a disk, and not an annulus, because the plusface  $\{a, b\}$  of  $\{a, b, d\}$  is self-identified. The union of the three cubes is thus a solid 3-ball with boundary the 2-sphere pictured in Figure 3.  $\square$

**Proof.** [of Theorem 1.2 (2).] The methods of [11] were used to establish this by Maple programs. Briefly, Lemma 5.1 and the cubical structure of  $\tilde{Q}_{n,i}$  are used to compute the homology groups by enumerating all relevant graphs and then considering the cubes corresponding to each graph. For copies of the specific programs used and the output files, see:

<http://www.math.uno.edu/~jensen/maple>  $\square$

**Proof.** [of Theorem 1.2 (3).] As mentioned in the introduction, we have a spectral sequence

$$E_{r,s}^2 = H_r(\text{Aut}(F_n); H_s(F_n; \mathbb{Q})) \Rightarrow H_{r+s}(F_n \rtimes \text{Aut}(F_n); \mathbb{Q}).$$

The  $E^2$ -page is 0 except in the row  $s = 0$ , where it is  $H_r(\text{Aut}(F_n); \mathbb{Q})$ , and the row  $s = 1$ , where it is  $H_r(\text{Aut}(F_n); \mathbb{Q}^n)$ . From [11],  $H_r(\text{Aut}(F_n); \mathbb{Q}) = 0$  for  $1 \leq$

$r \leq 6$ ,  $n \geq 1$ , except in the case  $r = n = 4$  where  $H_r(\text{Aut}(F_n); \mathbb{Q}) = \mathbb{Q}$ . Combining this with Theorem 1.2 (2) yields the desired result. The only exceptional cases are where  $n = 3$  and  $n = 4$ . When  $n = 3$ ,  $H_4(F_3 \rtimes \text{Aut}(F_3); \mathbb{Q}) = \mathbb{Q}$  and  $H_4(\text{Aut}(F_3); \mathbb{Q}) = H_5(\text{Aut}(F_3); \mathbb{Q}) = 0$ , forcing  $H_3(\text{Aut}(F_3); \mathbb{Q}^3) = \mathbb{Q}$ . When  $n = 4$ ,  $H_4(F_4 \rtimes \text{Aut}(F_4); \mathbb{Q}) = H_4(\text{Aut}(F_4); \mathbb{Q}) = \mathbb{Q}$  and  $H_5(\text{Aut}(F_4); \mathbb{Q}) = 0$ , forcing  $H_3(\text{Aut}(F_4); \mathbb{Q}^3) = 0$ .  $\square$

## References

- [1] G. Allison, A. Ash, E. Conrad, *Galois representations, Hecke operators, and the mod- $p$  cohomology of  $GL(3, \mathbb{Z})$  with twisted coefficients*, Experiment. Math. 7 (1998) 361-390.
- [2] A. Borel, Stable real cohomology of arithmetic groups. II., *Manifolds and Lie groups: papers in honor of Yozo Matsushima*, eds J. Hano et al., pp. 21-55, Birkhauser Boston 1981.
- [3] K. Brown, *Cohomology of Groups*, Springer-Verlag Berlin, Heidelberg 1982.
- [4] R. Charney, *Homology stability for  $GL_n$  of a Dedekind domain*, Invent. Math. 56 (1980) 1-17.
- [5] D. J. Collins, *Cohomological dimension and symmetric automorphisms of a free group*, Comment. Math. Helv. 64 (1989) 44-61.
- [6] M. Culler and K. Vogtmann, *Moduli spaces of graphs and automorphisms of free groups*, Invent. Math. 84 (1986) 91-119.
- [7] W. G. Dwyer, *Twisted homological stability for general linear groups*, Ann. Math. (2) 111 (1980) 239-251.
- [8] H. H. Glover and C. A. Jensen, *Geometry for palindromic automorphism groups of free groups*, Comment. Math. Helv. 75 (2000) 644-667.
- [9] A. Hatcher, *Homological stability for automorphism groups of free groups*, Comment. Math. Helv. 70 (1995) 39-62.
- [10] A. Hatcher and K. Vogtmann, *Cerf theory for graphs*, J. London Math. Soc. (2) 58 (1998) 633-655.
- [11] A. Hatcher and K. Vogtmann, *Rational homology of  $\text{Aut}(F_n)$* , Math. Res. Lett. 5 (1998) 759-780.
- [12] C. A. Jensen, *Cohomology of  $\text{Aut}(F_n)$* , Cornell University Ph.D. dissertation, Ithaca, New York 1998.
- [13] C. A. Jensen, *Cohomology of  $\text{Aut}(F_n)$  in the  $p$ -rank two case*, J. Pure Appl. Algebra 159 (2001) 41-81.



- [14] C. A. Jensen, *Contractibility of fixed point sets of outer space*, Topology Appl. 119 (2002) 287-304.
- [15] D. McCullough and A. Miller, *Symmetric Automorphisms of Free Products*, Mem. Amer. Math. Soc. 122 (1996), no. 582.
- [16] M. Nakaoka, *Decomposition Theorem for Homology Groups of Symmetric Groups*, Ann. Math. 71 (1960) 16-42.
- [17] J. Smillie and K. Vogtmann, *A generating function for the Euler characteristic of  $Out(F_n)$* , J. Pure Appl. Algebra 44 (1987) 329-348.
- [18] S. Thomas and B. Velickovic, *On the Complexity of the Isomorphism Relation for Finitely Generated Groups*, J. Algebra 217 (1999) 352-373.